

INTERNATIONAL STANDARD

IEC
60917-2-3

First edition
2006-05

**Modular order for the development
of mechanical structures –
for electronic equipment practices –**

**Part 2-3:
Sectional specification –
Interface co-ordination dimensions
for the 25 mm equipment practice –
Extended detail specification –
Dimensions for subracks, chassis, backplanes,
front panels and plug-in units**



Reference number
IEC 60917-2-3:2006(E)

Publication numbering

As from 1 January 1997 all IEC publications are issued with a designation in the 60000 series. For example, IEC 34-1 is now referred to as IEC 60034-1.

Consolidated editions

The IEC is now publishing consolidated versions of its publications. For example, edition numbers 1.0, 1.1 and 1.2 refer, respectively, to the base publication, the base publication incorporating amendment 1 and the base publication incorporating amendments 1 and 2.

Further information on IEC publications

The technical content of IEC publications is kept under constant review by the IEC, thus ensuring that the content reflects current technology. Information relating to this publication, including its validity, is available in the IEC Catalogue of publications (see below) in addition to new editions, amendments and corrigenda. Information on the subjects under consideration and work in progress undertaken by the technical committee which has prepared this publication, as well as the list of publications issued, is also available from the following:

- **IEC Web Site (www.iec.ch)**
- **Catalogue of IEC publications**

The on-line catalogue on the IEC web site (www.iec.ch/searchpub) enables you to search by a variety of criteria including text searches, technical committees and date of publication. On-line information is also available on recently issued publications, withdrawn and replaced publications, as well as corrigenda.
- **IEC Just Published**

This summary of recently issued publications (www.iec.ch/online_news/justpub) is also available by email. Please contact the Customer Service Centre (see below) for further information.
- **Customer Service Centre**

If you have any questions regarding this publication or need further assistance, please contact the Customer Service Centre:

Email: custserv@iec.ch
Tel: +41 22 919 02 11
Fax: +41 22 919 03 00

INTERNATIONAL STANDARD

IEC 60917-2-3

First edition
2006-05

Modular order for the development of mechanical structures for electronic equipment practices –

Part 2-3: Sectional specification – Interface co-ordination dimensions for the 25 mm equipment practice – Extended detail specification – Dimensions for subracks, chassis, backplanes, front panels and plug-in units

© IEC 2006 — Copyright - all rights reserved

No part of this publication may be reproduced or utilized in any form or by any means, electronic or mechanical, including photocopying and microfilm, without permission in writing from the publisher.

International Electrotechnical Commission, 3, rue de Varembé, PO Box 131, CH-1211 Geneva 20, Switzerland
Telephone: +41 22 919 02 11 Telefax: +41 22 919 03 00 E-mail: inmail@iec.ch Web: www.iec.ch



Commission Electrotechnique Internationale
International Electrotechnical Commission
Международная Электротехническая Комиссия

PRICE CODE

V

For price, see current catalogue

CONTENTS

FOREWORD.....	4
INTRODUCTION.....	6
1 Scope and object.....	8
2 Normative references	8
3 Terms and definitions	9
4 Arrangement overview.....	9
5 Subrack dimensions for injector/extractor handle of plug-in units.....	10
5.1 Subrack interface dimensions.....	10
6 Dimensions of injector/extractor handle for plug-in units	12
6.1 Injector/extractor handle interface dimensions.....	12
6.2 Handle-locking function	14
7 Subrack and plug-in units with electromagnetic shielding provision	14
7.1 Subrack interface dimensions for electromagnetic shielding provision	14
7.2 Front panel/plug-in unit interface dimensions	17
8 Key/coding system for subrack and plug-in units	18
8.1 Subrack interface dimensions – Key/coding system on the plug-in unit guides	19
8.2 Key dimensions – Key/coding system on the plug-in unit guides.....	20
8.3 Programming of key – Key/coding system on the plug-in guides.....	22
8.4 Keying chamber inspection dimensions	22
9 Alignment pin and/or electrical contact for front panels and plug-in units	23
9.1 Alignment pins and receptacle plates on the subrack horizontal members	24
9.2 Alignment and/or electrical contact pins and receptacles on the subrack plug-in unit guides.....	25
10 Electrostatic discharge provision for plug-in units and subracks.....	27
10.1 ESD contact interface dimensions	28
10.2 ESD strip interface dimensions.....	28
11 Subrack dimensions for rear-mounted plug-in units	32
 Annex A Subrack, plug-in unit and backplane dimensions for using metric connectors.....	 33
 Figure 1 – Typical example of large subracks in a wide cabinet, equipped mass volume of copper/optical cables installation	 7
Figure 2 – Subject for development of extended connector application packaging and key elements of interconnection between functional plug-in modules via backplane in the future packaging system	7
Figure 3 – Arrangement overview	9
Figure 4 – Subrack interface dimensions, injector/extractor handles for plug-in units	11
Figure 5 – Detail X and detail Y, subrack interface dimensions, injection/extraction handles for plug-in units.....	12
Figure 6 – Plug-in units interface dimensions, injection/extraction handle for plug-in units ...	13
Figure 7 – Detail X and detail Y, plug-in interface dimensions, injector/extractor handles for plug-in units.....	14
Figure 8 – Subrack interface dimensions, electromagnetic shielding provisions	15

Figure 9 – Detail X and detail Y, subrack interface dimensions, electromagnetic shielding provisions	16
Figure 10 – Front panel/plug-in unit interface dimensions, electromagnetic shielding provisions	17
Figure 11 – Arrangement of key/coding system for plug-in units.....	18
Figure 12 – Subrack interface dimensions – Key/coding system on the plug-in unit guides.....	19
Figure 13 – Plug-in unit interface dimensions – Key/coding system on the plug-in unit guides.....	20
Figure 14 – Key dimensions and rotated key positions – Key/coding system on the plug-in unit guides	21
Figure 15 – Programming of keys	22
Figure 16 – Arrangement of alignment pin system for subracks and plug-in units.....	23
Figure 17 – Subrack interface dimensions, alignment pins and receptacle plates on the horizontal members	24
Figure 18 – Plug-in unit interface dimensions, alignment pins and receptacle plates on the horizontal members	25
Figure 19 – Subrack interface dimensions, alignment and/or electrical contact pin receptacles on the plug-in unit guides	26
Figure 20 – Plug-in unit interface dimensions, alignment and/or electrical contact pin receptacles on the plug-in unit guides	27
Figure 21 – Subrack interface dimensions, ESD contacts on the plug-in guides	28
Figure 22 – Plug-in unit interface dimensions, ESD strips on the plug-in boards	29
Figure 23 – Subrack dimensions for rear mounted plug-in units	32
Figure A.1 – Subrack, plug-in unit and backplane dimensions for using 2,5 mm metric connectors in accordance with IEC 61076-4-100.....	33
Figure A.2 – Subrack, plug-in unit and backplane dimensions for using 2 mm metric connectors in accordance with IEC 61076-4-101.....	34
Figure A.3 – Subrack, plug-in unit and backplane dimensions for using 2 mm metric connectors in accordance with IEC 61076-4-104.....	35
Table 1 – Inspection dimensions of subrack and plug-in unit keying chambers.....	22
Table 2 – Dimensions of subracks and plug-in units based on IEC 60917-2-2.....	30
Table 3 – Dimensions of subracks and boards for rear-mounted plug-in units	32

INTERNATIONAL ELECTROTECHNICAL COMMISSION

**MODULAR ORDER FOR THE DEVELOPMENT
OF MECHANICAL STRUCTURES
FOR ELECTRONIC EQUIPMENT PRACTICES –**

**Part 2-3: Sectional specification – Interface co-ordination dimensions
for the 25 mm equipment practice – Extended detail specification –
Dimensions for subracks, chassis, backplanes, front panels
and plug-in units**

FOREWORD

- 1) The International Electrotechnical Commission (IEC) is a worldwide organization for standardization comprising all national electrotechnical committees (IEC National Committees). The object of IEC is to promote international co-operation on all questions concerning standardization in the electrical and electronic fields. To this end and in addition to other activities, IEC publishes International Standards, Technical Specifications, Technical Reports, Publicly Available Specifications (PAS) and Guides (hereafter referred to as “IEC Publication(s)”). Their preparation is entrusted to technical committees; any IEC National Committee interested in the subject dealt with may participate in this preparatory work. International, governmental and non-governmental organizations liaising with the IEC also participate in this preparation. IEC collaborates closely with the International Organization for Standardization (ISO) in accordance with conditions determined by agreement between the two organizations.
- 2) The formal decisions or agreements of IEC on technical matters express, as nearly as possible, an international consensus of opinion on the relevant subjects since each technical committee has representation from all interested IEC National Committees.
- 3) IEC Publications have the form of recommendations for international use and are accepted by IEC National Committees in that sense. While all reasonable efforts are made to ensure that the technical content of IEC Publications is accurate, IEC cannot be held responsible for the way in which they are used or for any misinterpretation by any end user.
- 4) In order to promote international uniformity, IEC National Committees undertake to apply IEC Publications transparently to the maximum extent possible in their national and regional publications. Any divergence between any IEC Publication and the corresponding national or regional publication shall be clearly indicated in the latter.
- 5) IEC provides no marking procedure to indicate its approval and cannot be rendered responsible for any equipment declared to be in conformity with an IEC Publication.
- 6) All users should ensure that they have the latest edition of this publication.
- 7) No liability shall attach to IEC or its directors, employees, servants or agents including individual experts and members of its technical committees and IEC National Committees for any personal injury, property damage or other damage of any nature whatsoever, whether direct or indirect, or for costs (including legal fees) and expenses arising out of the publication, use of, or reliance upon, this IEC Publication or any other IEC Publications.
- 8) Attention is drawn to the Normative references cited in this publication. Use of the referenced publications is indispensable for the correct application of this publication.
- 9) Attention is drawn to the possibility that some of the elements of this IEC Publication may be the subject of patent rights. IEC shall not be held responsible for identifying any or all such patent rights.

International Standard IEC 60917-2-3 has been prepared by subcommittee 48D: Mechanical structures for electronic equipment, of IEC technical committee 48: Electromechanical components and mechanical structures for electronic equipment.

The text of this standard is based on following documents:

FDIS	Report on voting
48D/338/FDIS	48D/342/RVD

Full information on the voting for the approval of this standard can be found in the report on voting indicated in the above table.

IEC 60917 consists of the following parts, under the general title *Modular order for the development of mechanical structures for electronic equipment practices*:

- Part 1: Generic standard
- Part 2: Sectional specification – Interface co-ordination dimensions for the 25 mm equipment practice
- Part 2-1: Sectional specification – Interface co-ordination dimensions for the 25 mm equipment practice – Detail specification – Dimensions for cabinets and racks
- Part 2-2: Sectional specification – Interface co-ordination dimensions for the 25 mm equipment practice – Detail specification – Dimensions for subracks, chassis, backplanes, front panels and plug-in units
- Part 2-3: Sectional specification – Interface co-ordination dimensions for the 25 mm equipment practice – Extended detail specification – Dimensions for subracks, chassis, backplanes, front panels and plug-in units

The committee has decided that the contents of this publication will remain unchanged until the maintenance result date indicated on the IEC web site under "<http://webstore.iec.ch>" in the data related to the specific publication. At this date, the publication will be

- reconfirmed;
- withdrawn;
- replaced by a revised edition, or
- amended.

A bilingual version of this publication may be issued at a later date.

INTRODUCTION

The dimensions in the detail specification for the 25 mm equipment practice standard are laid down in the IEC 60917-2 series.

Significant progress in electronics circuitry, with increasing signal speed and the demand for high availability of the electronics systems, has made an impact on the structural parts of the equipment, as specified in IEC 60917-2-2.

a) Considerations on the general tendency of the enclosure system

At the moment, the general tendencies of the enclosure system for telecom/IT equipment application and associated application are considered to be:

- the changing form of conventional centralized networking for telecommunication to flexible distributed networking to realize ubiquitous communication and computing environment by broad-band/IP and photonics-networking-based technology;
- flexible configuration of networking equipment from the open market is requested;
- a scalable and high-performance packaging/enclosure system is requested for new networking equipment;
- in addition, such a packaging/enclosure system will be widely applied for general electronic equipment, because IP networking technology is becoming one of the common interfaces for all of industrial systems.

Consequently, the following general requirements for the new enclosure system arise.

- Standard-based but various sized networking/IT equipment from the open market should be installed in one cabinet (see figure 1).
- The mass volume of copper/optical cables from the equipment should be managed in the cabinet.
- Networking/IT cabinets will be increasingly sited at general offices in enterprise buildings rather than at traditional technical rooms in telecom-central offices.

In order to meet these market needs, the implementation of additional specified dimensions for extended features based on IEC 60917-2-2 became necessary.

b) Subject for development of extended connector application packaging based on IEC 60917 series

The existing IEC 60917 series, which is structured on the modular concept of 25 mm, is based on the IEC standardized metric connector. However, the system packaging uses to many non-standardized enhanced connectors, which are necessary to realize the system functions and level of performance (see Figure 2).

NOTE IEC Subcommittee 48D, Working Group 2, reviews the trends in system packaging, in which key elements are electrical/optical signal interfaces and connectors, as well as the general tendency of the new enclosure system. From these aspects, the IEC Subcommittee 48D, Working Group 2 has recently developed IEC 60917-2-3 which will be applicable to system packaging for high-speed and other system applications in the near future.

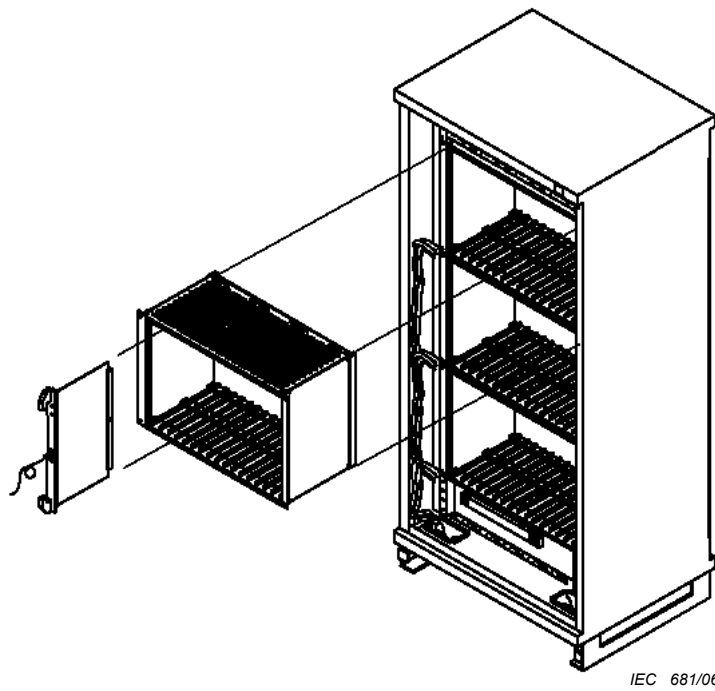

IEC 681/06

Figure 1 – Typical example of large subracks in a wide cabinet, equipped mass volume of copper/optical cables installation

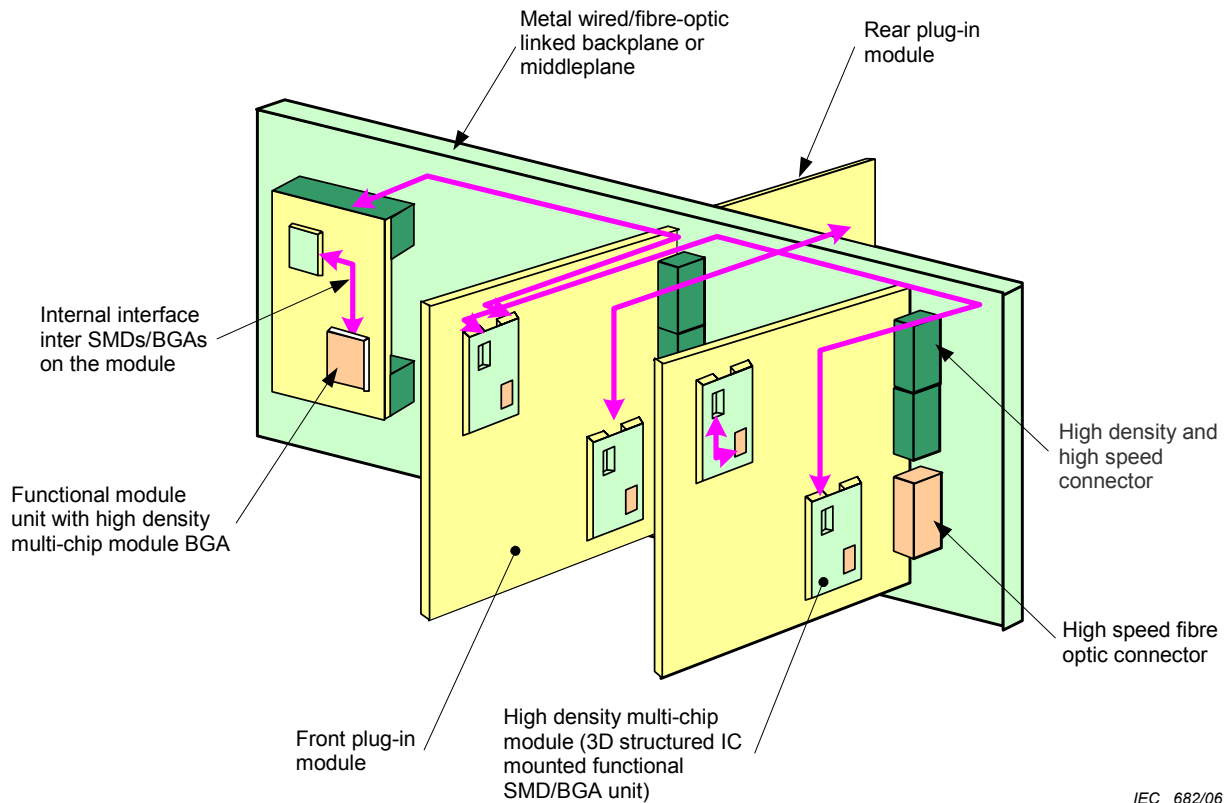

IEC 682/06

Key

SMD: Surface Mount Device.

BGA: Ball Grid Array.

Figure 2 – Subject for development of extended connector application packaging and key elements of interconnection between functional plug-in modules via backplane in the future packaging system

MODULAR ORDER FOR THE DEVELOPMENT OF MECHANICAL STRUCTURES FOR ELECTRONIC EQUIPMENT PRACTICES –

Part 2-3: Sectional specification – Interface co-ordination dimensions for the 25 mm equipment practice – Extended detail specification – Dimensions for subracks, chassis, backplanes, front panels and plug-in units

1 Scope and object

This part of IEC 60917 provides additional dimensions for a modular range of subracks and associated plug-in units based on IEC 60917-2-2.

A typical subrack consists of a frame design with mounting dimensions for installation into racks or cabinets in accordance with IEC 60917-2-1. The aperture dimensions of a subrack are specified in order to meet the mounting dimensions of front plug-in units.

This part of IEC 60917 comprises

- additional dimensions for subracks and subrack associated plug-in units with injector/extractor handle;
- dimensions for basic electromagnetic shielding provisions;
- dimensions of the key/coding system for subrack and plug-in units;
- dimensions of the alignment pin for front panel and plug-in unit;
- dimensions of electrostatic discharge provisions;
- dimensions of rear-mounted plug-in units.

Connector-related dimensions are given in Annex A.

In order to ensure the compatibility of plug-in units into the subrack, inspection dimensions and connector-dependent dimensions are defined.

NOTE The drawings used in this part of IEC 60917 are not intended to indicate product design, only the specific dimensions that are used.

2 Normative references

The following referenced documents are indispensable for the application of this document. For dated references, only the edition cited applies. For undated references, the latest edition of the referenced document (including any amendments) applies.

IEC 60917-1:1998, *Modular order for the development of mechanical structures for electronic equipment practices – Part 1: Generic standard*

IEC 60917-2-1:1993, *Modular order for the development of mechanical structures for electronic equipment practice – Part 2: Sectional specification – Interface co-ordination dimensions for the 25 mm equipment practice – Section 1: Detail specification – Dimensions for cabinets and racks*

IEC 60917-2-2:1994, *Modular order for the development of mechanical structures for electronic equipment practice – Part 2: Sectional specification – Interface co-ordination dimensions for the 25 mm equipment practice – Section 2: Detail specification – Dimensions for subracks, chassis, backplanes, front panels and plug-in units*

IEC 61076-4-100:2001, *Connectors for electronic equipment – Part 4-100: Printed board connectors with assessed quality – Detail specification for two-part connector modules having a grid of 2,5 mm for printed boards and backplanes*

IEC 61076-4-101:2001, *Connectors for electronic equipment – Part 4-101: Printed board connectors with assessed quality – Detail specification for two-part connector modules, having a basic grid of 2,0 mm for printed boards and backplane in accordance with IEC 60917*

IEC 61076-4-104:1999, *Connectors for use in d.c., low frequency analogue and digital high speed data application – Part 4-104: Printed board connectors with assessed quality – Detail specification for two-part modular connectors, basic grid of 2,0 mm, with terminations on a multiple grid of 0,5 mm*

3 Terms and definitions

For the purposes of this document, the terms and definitions given in IEC 60917-1 apply.

4 Arrangement overview

Typical subrack with front and rear plug-in units (see Figure 3).

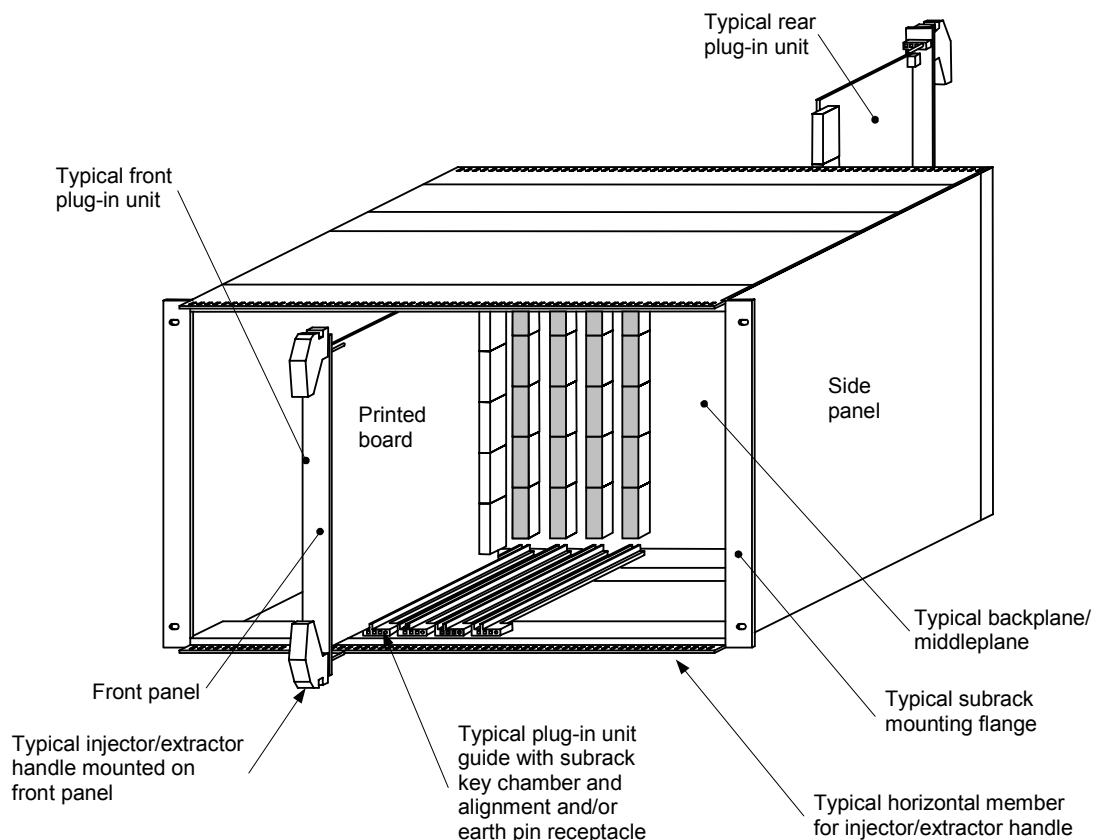

IEC 683/06

Figure 3 – Arrangement overview

5 Subrack dimensions for injector/extractor handle of plug-in units

5.1 Subrack interface dimensions

The following subrack interface dimensions shall be used only for applications with enhanced injector/extractor handles that are defined in Clause 6 of this part of IEC 60917.

The basic dimensions of the subrack are in accordance with IEC 60917-2-2. Only the additional dimensions of the subrack and plug-in units with the injector/extractor handles are specified in this clause (see Figures 4 and 5).

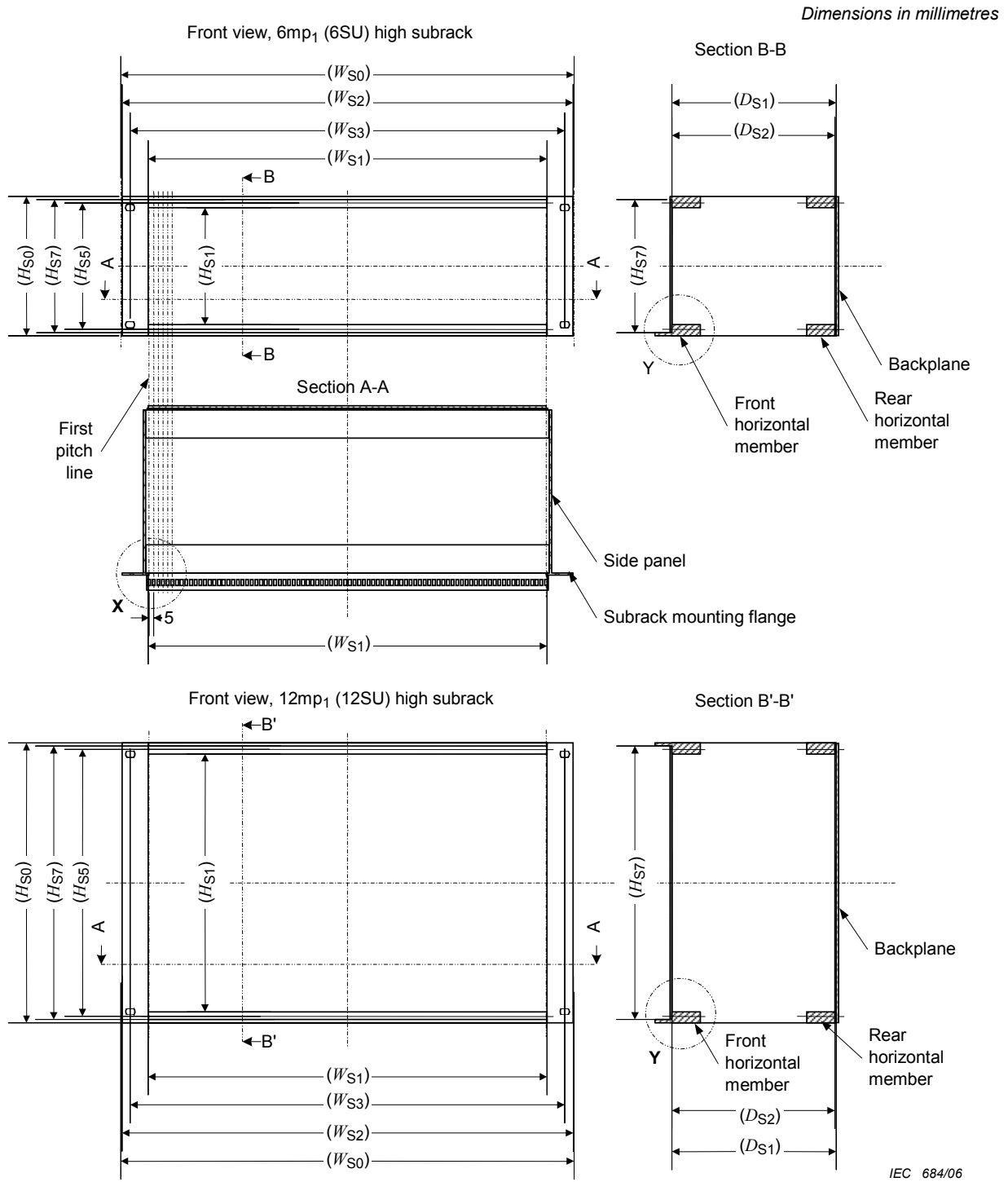

NOTE Dimensions in parentheses are in accordance with IEC 60917-2-2 (see Table 2).

Figure 4 – Subrack interface dimensions, injector/extractor handles for plug-in units

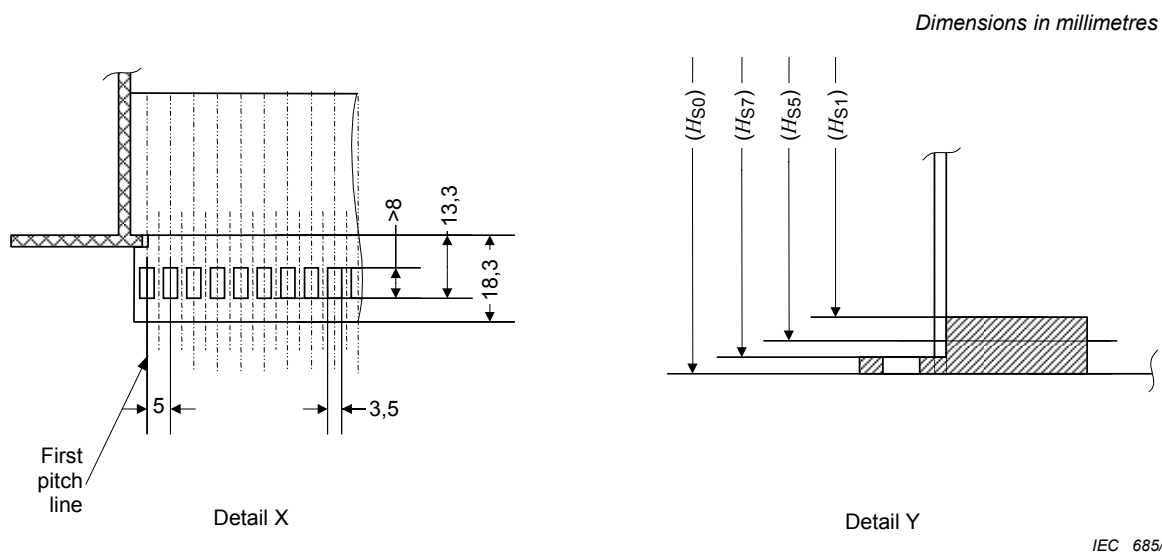

NOTE Dimensions in parentheses are in accordance with IEC 60917-2-2 (see Table 2).

Figure 5 – Detail X and detail Y, subrack interface dimensions, injection/extraction handles for plug-in units

6 Dimensions of injector/extractor handle for plug-in units

6.1 Injector/extractor handle interface dimensions

The following handle interface dimensions shall be used only for applications with subracks that have the interface dimensions for injector/extractor handles and that are defined in Clause 5 of this part of IEC 60917.

The basic dimensions of the plug-in units are in accordance with IEC 60917-2-2. Only the additional dimensions of the plug-in units with the injector/extractor handles are specified in this clause (see Figures 6 and 7).

The width of the injector/extractor handles can have any dimension less than Ws_4 , front panel width. See Table 2b.

The injector/extractor handles may exceed the horizontal pitch lines defined in 60917-2-2 to obtain effective injection/extraction function. The handle in closed position shall not exceed the subrack reference plane. In operation of insertion and extraction, the handle may exceed by maximum 0,5 mp 1 (0,5 SU) to the subrack (height) reference plane on both sides, top and bottom.

NOTE It is recommended that, in respect to the connector insertion/withdrawal force, the handle should be of such a design, that the force to operate the handle should not exceed 100 N.

Dimensions in millimetres

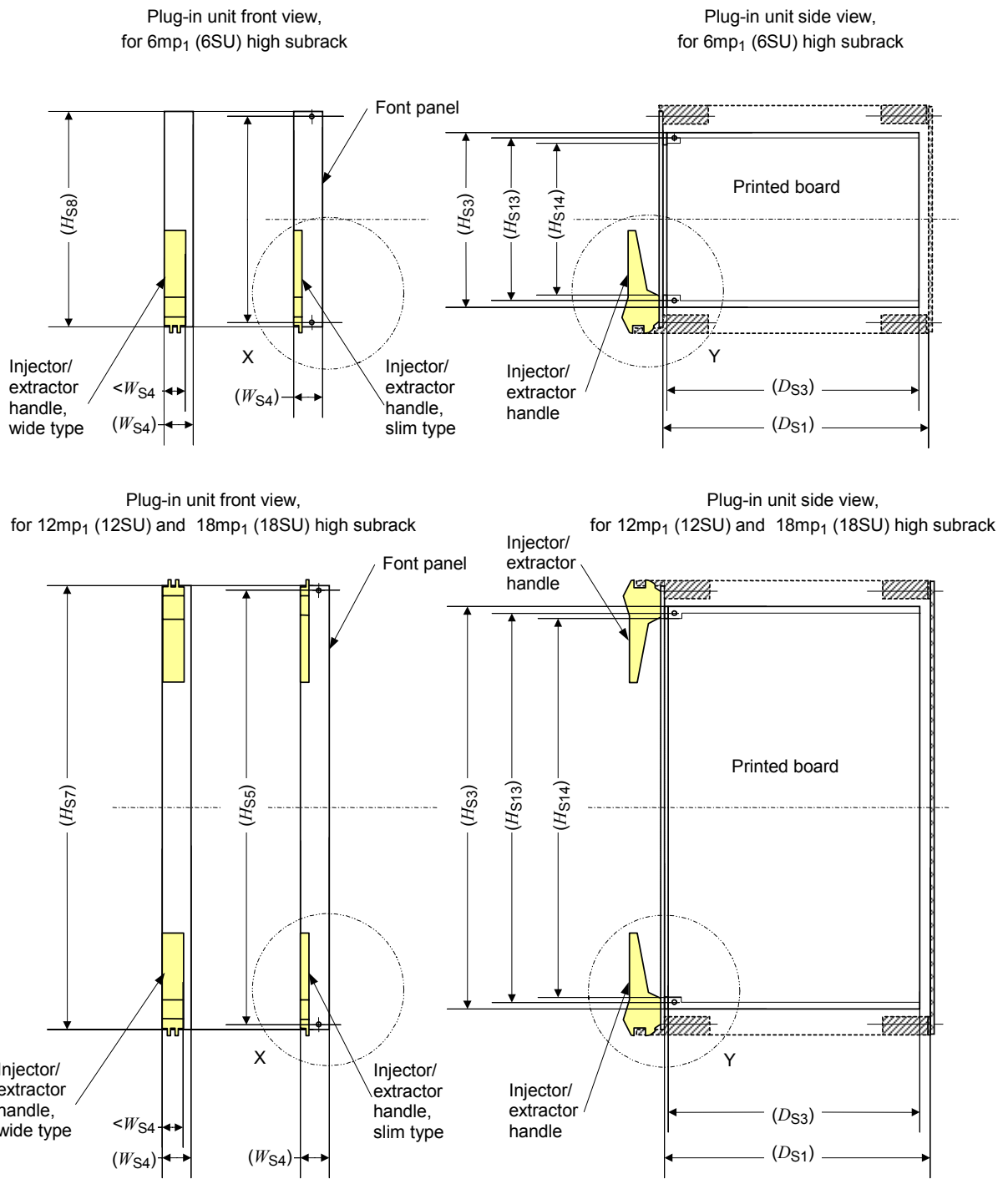

IEC 686/06

NOTE Dimensions in parentheses are in accordance with IEC 60917-2-2 (see Table 2).

Figure 6 – Plug-in units interface dimensions, injection/extraction handle for plug-in units

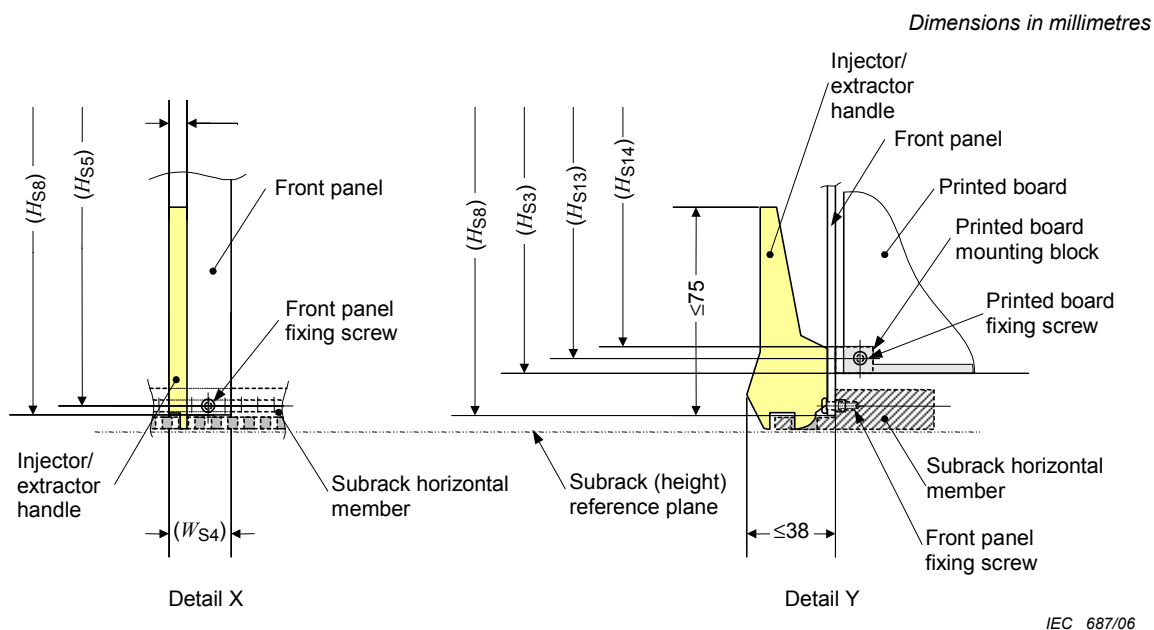

NOTE Dimensions in parentheses are in accordance with IEC 60917-2-2 (see Table 2).

Figure 7 – Detail X and detail Y, plug-in interface dimensions, injector/extractor handles for plug-in units

6.2 Handle-locking function

The injector/extractor handle may have a locking function instead of a plug-in unit fixing screw.

7 Subrack and plug-in units with electromagnetic shielding provision

7.1 Subrack interface dimensions for electromagnetic shielding provision

The following subrack interface dimensions shall be used only for applications with plug-in units that have electromagnetic shielding provisions as defined in 7.2 of this part of IEC 60917.

The basic dimensions of the subrack are in accordance with IEC 60917-2-2 for subracks, front panels and plug-in units. Only the additional dimensions of the subrack with the electromagnetic shielding provision are specified in this clause (see Figures 8 and 9).

The width of the injector/extractor handle can have any dimension less than W_{S4} , front panel width (see Table 2).

The injector/extractor handles may exceed the horizontal pitch lines defined in IEC 60917-2-2 to obtain effective injection/extraction function.

The handle in closed position shall not exceed the subrack reference plane. In the operations of insertion and extraction, the handle may exceed the subrack (height) reference plane on both sides, top and bottom by a maximum of $0,5 mp_1$ (0,5 SU).

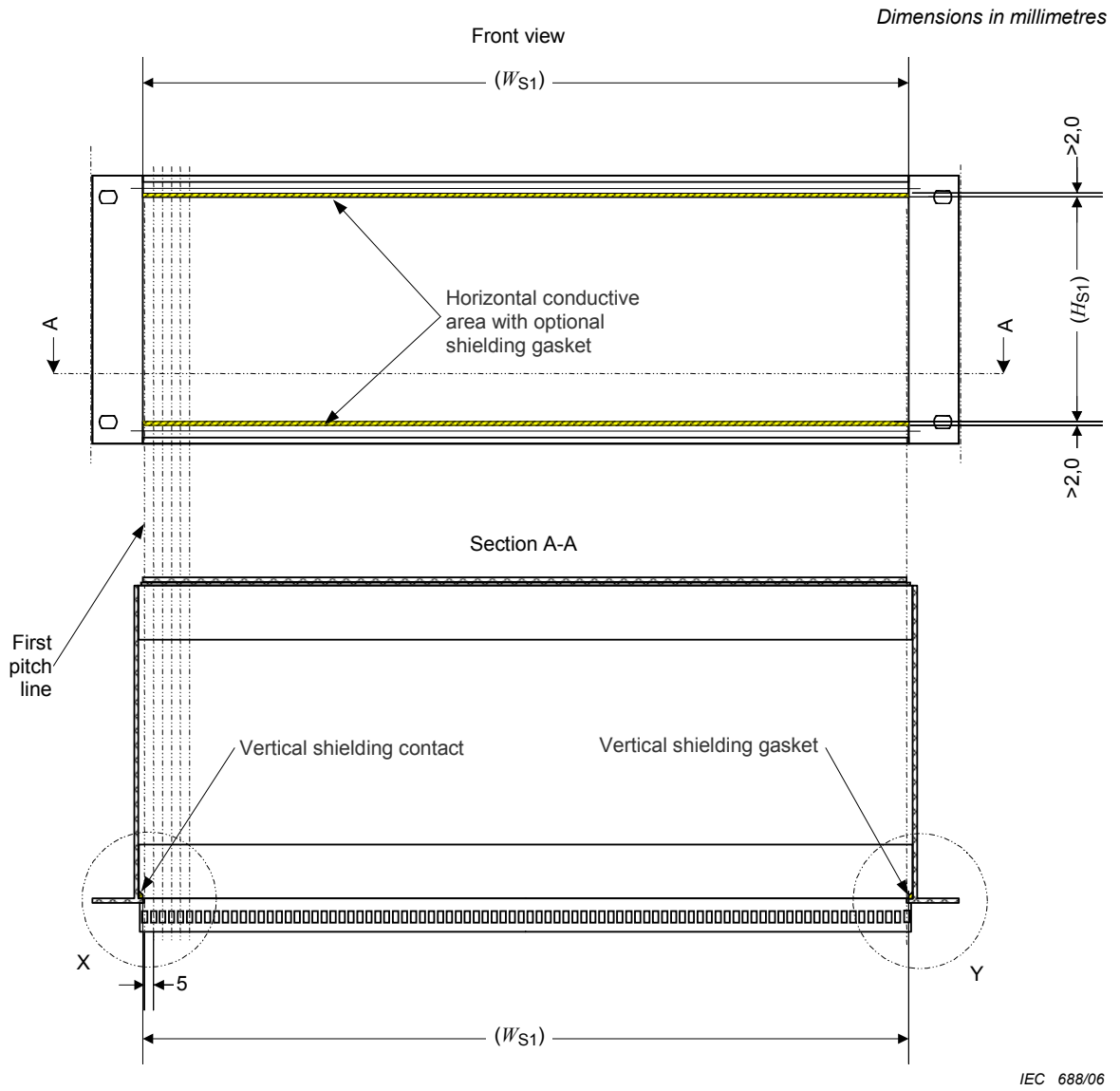

NOTE Dimensions in parenthesis are in accordance with IEC 60917-2-2 (see Table 2).

Figure 8 – Subrack interface dimensions, electromagnetic shielding provisions

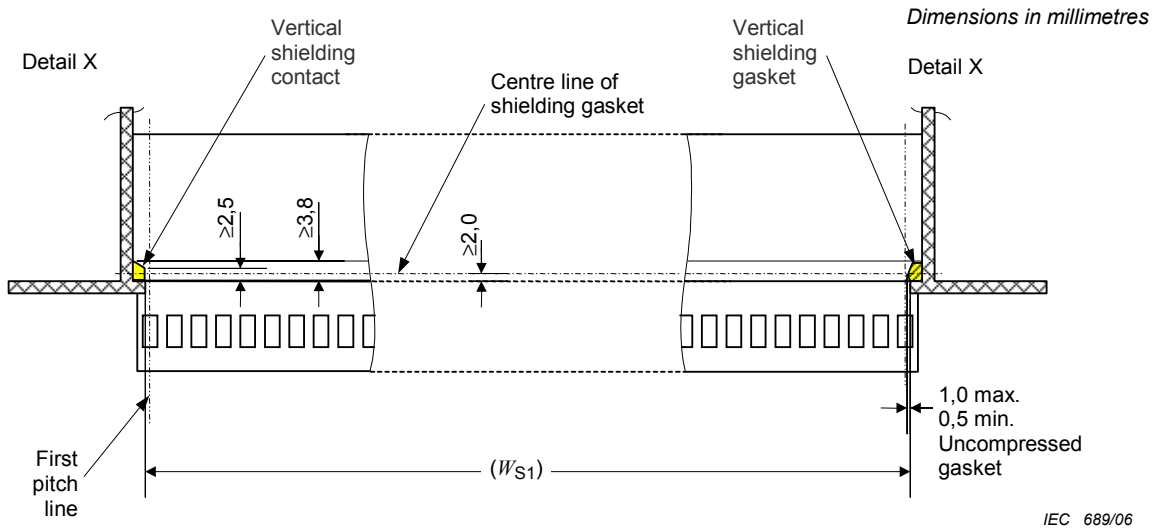

NOTE 1 Dimensions in parentheses are in accordance with IEC 60917-2-2 (see Table 2).

NOTE 2 It is recommended that shielding gaskets and shielding contact surfaces of low electrical resistance and long-lasting corrosion protection should be used.

Figure 9 – Detail X and detail Y, subrack interface dimensions, electromagnetic shielding provisions

7.2 Front panel/plug-in unit interface dimensions

The following front panel/plug-in units interface dimensions shall be used only for applications with subracks that have electromagnetic shielding provisions, as defined in 7.1 of this part of IEC 60917.

The basic dimensions of the front panel/plug-in unit are in accordance with IEC 60917-2-2 for subracks, front panels and plug-in units. Only the additional dimensions of the front panel/plug-in unit with the electromagnetic shielding provision are specified in this clause (see Figure 10).

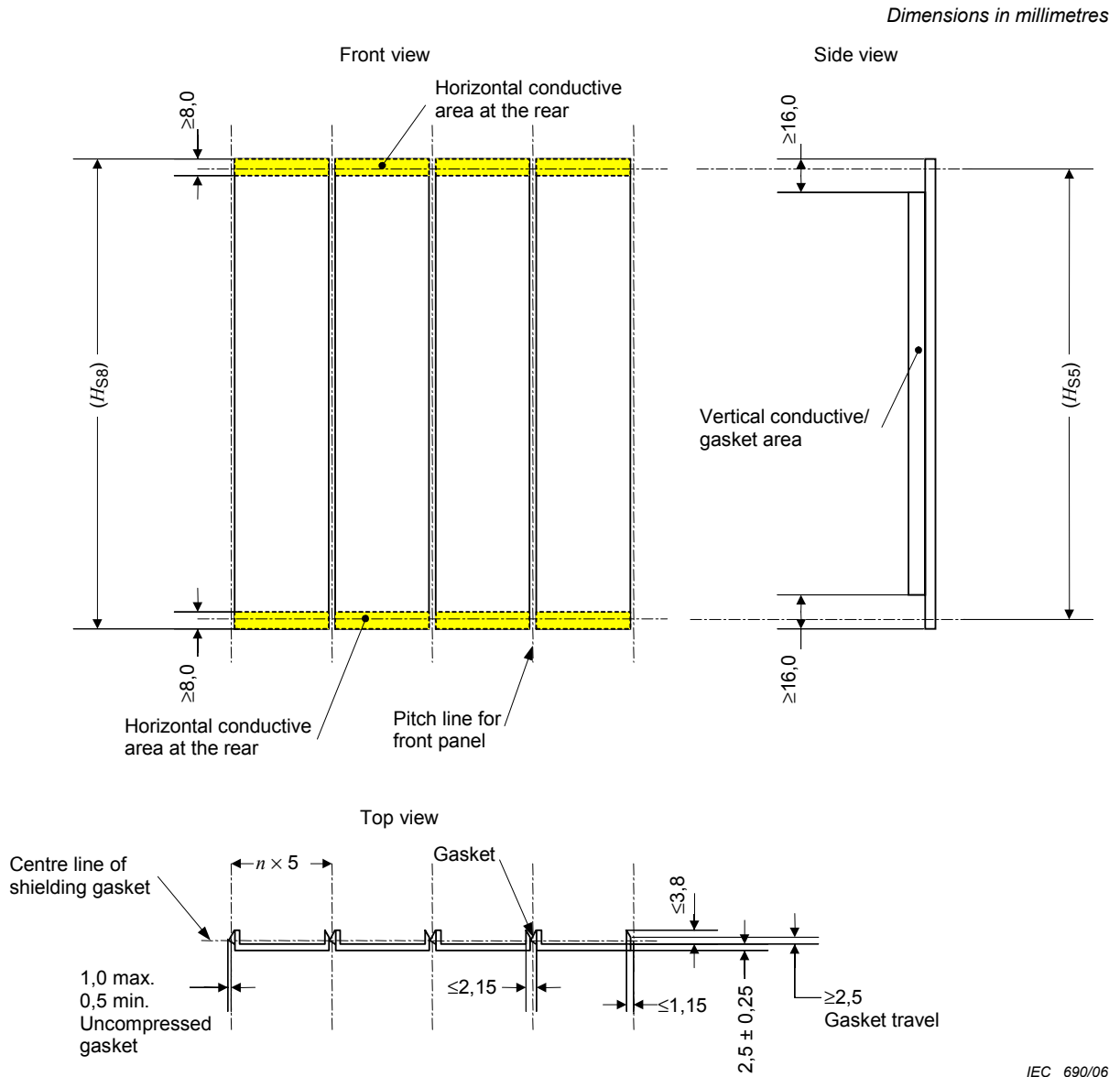

NOTE Dimensions in parentheses are in accordance with IEC 60917-2-2 (see Table 2).

Figure 10 – Front panel/plug-in unit interface dimensions, electromagnetic shielding provisions

8 Key/coding system for subrack and plug-in units

8.1 General

The subrack and plug-in units may have a key/coding system on the plug-in unit and the subrack plug-in unit guide. This part of IEC 60917 details a keying system that is user-programmable from the front and/or the rear of a subrack and on the rear face of a plug-in unit. The programmable key can be set, removed or changed by the users (see Figures 11, 12 and 13).

A subrack assembled with guide rails in accordance with IEC 60917-2-2 and Clause 11 of this part of IEC 60917 (without a keying feature) will accept plug-in units with front panels in accordance with this clause (with keys removed).

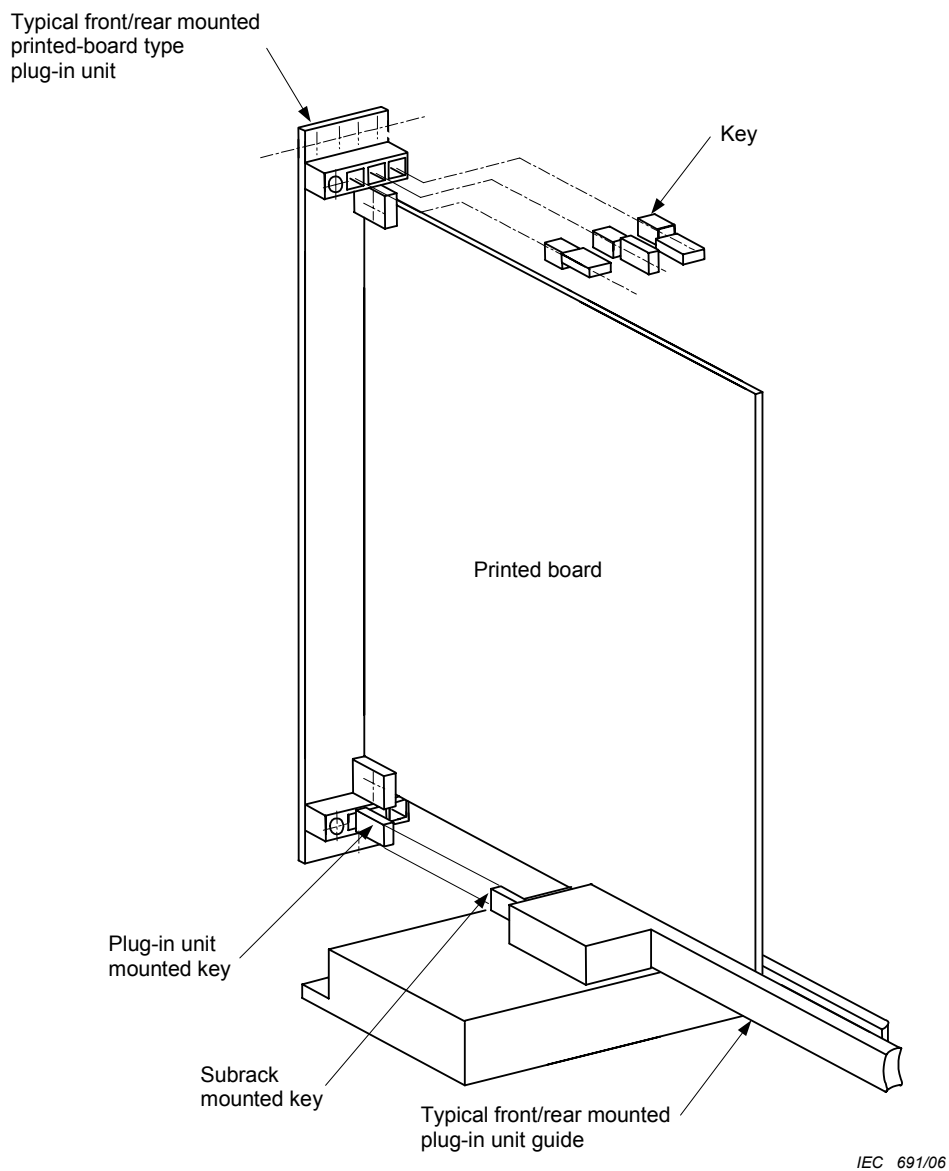
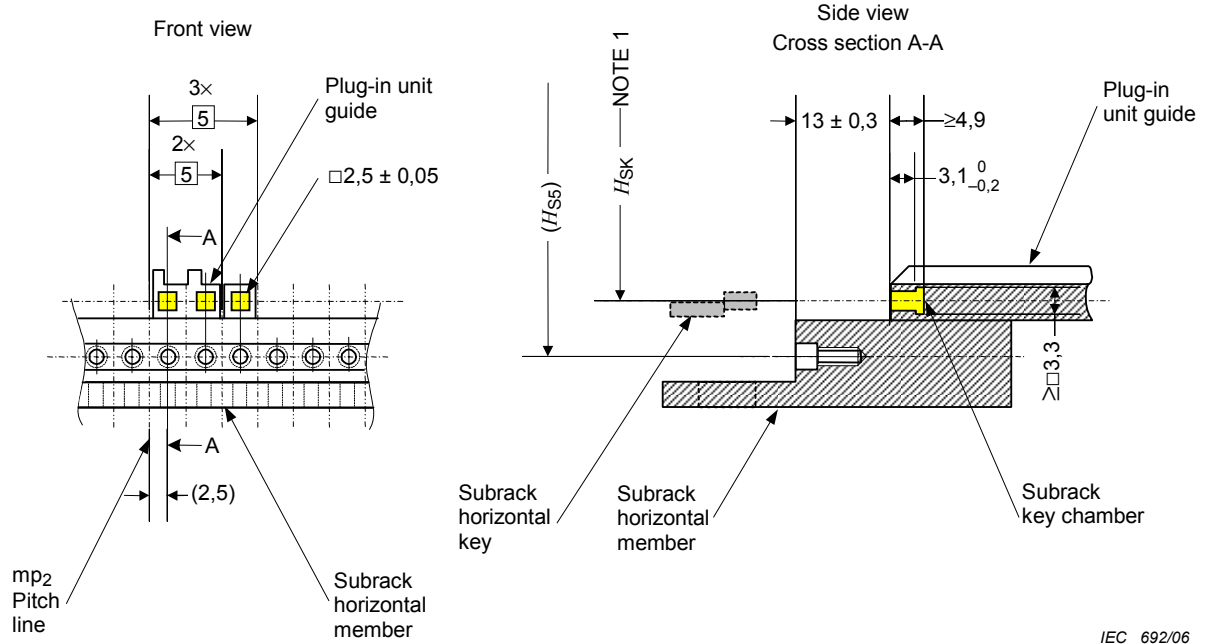

Figure 11 – Arrangement of key/coding system for plug-in units

8.2 Subrack interface dimensions – Key/coding system on the plug-in unit guides

Dimensions in millimetres



IEC 692/06

NOTE 1 For the H_{SK} dimension, see Table 1.

NOTE 2 Dimensions in parentheses are in accordance with IEC 60917-2-2 (see Table 2).

Figure 12 – Subrack interface dimensions – Key/coding system on the plug-in unit guides

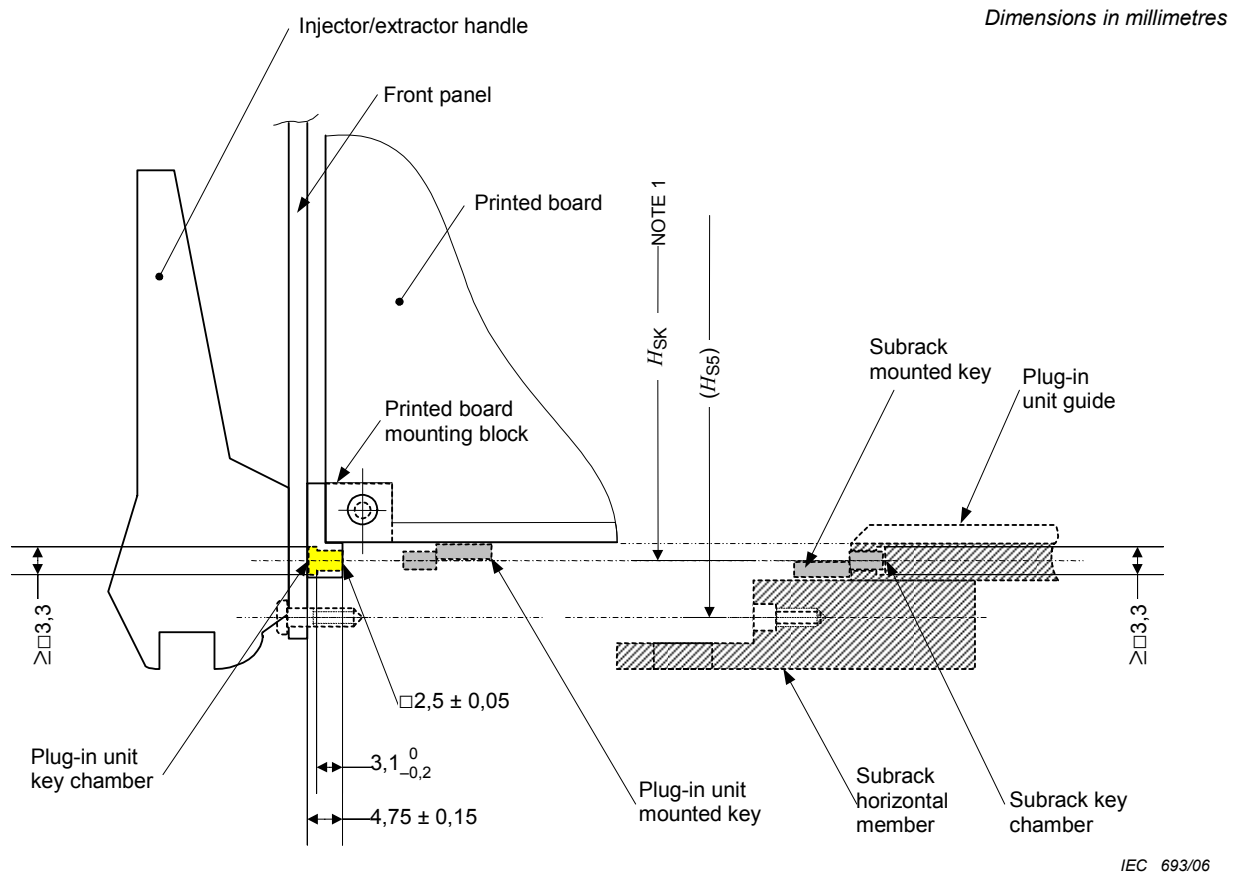

NOTE 1 For the H_{SK} dimension, see Table 1.

NOTE 2 Dimensions in parentheses are in accordance with IEC 60917-2-2 (see Table 2).

Figure 13 – Plug-in unit interface dimensions – Key/coding system on the plug-in unit guides

8.3 Key dimensions – Key/coding system on the plug-in unit guides

The key dimensions will allow the programming of four positions within one chamber of the subrack and the plug-in units respectively. The keys shall be designed for self-retaining snap-in assembly (see Figures 14 and 15).

The key chambers of the subracks and the plug-in units are identified by six letters; they are A, B, C, D, E and F (see Figure 15). Subracks of 6 mp_1 (6 SU) in height and associated plug-in units typically provide the keying chambers in the lower position that are identified by three letters, D, E and F. Subracks and plug-in units having a height of 12 mp_1 (12 SU) and 18 mp_1 (18 SU) may have the keying chamber in the upper and lower positions that are identified by six letters from A to F.

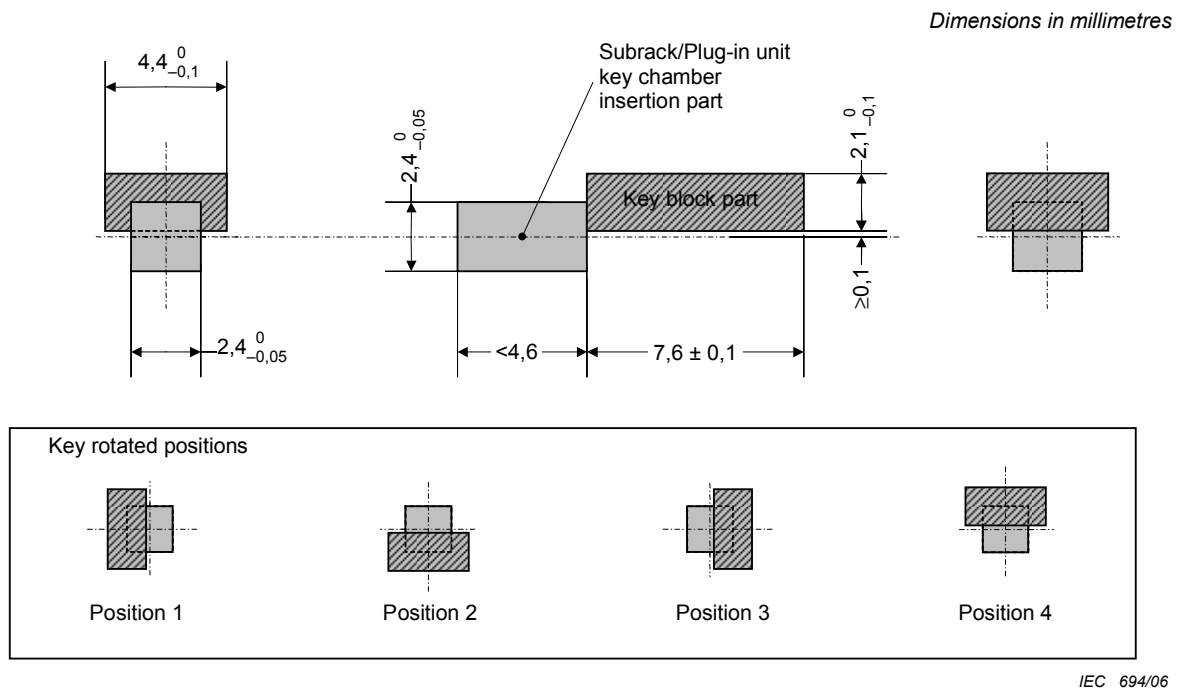

**Figure 14 – Key dimensions and rotated key positions –
Key/coding system on the plug-in unit guides**

8.4 Programming of key – Key/coding system on the plug-in guides

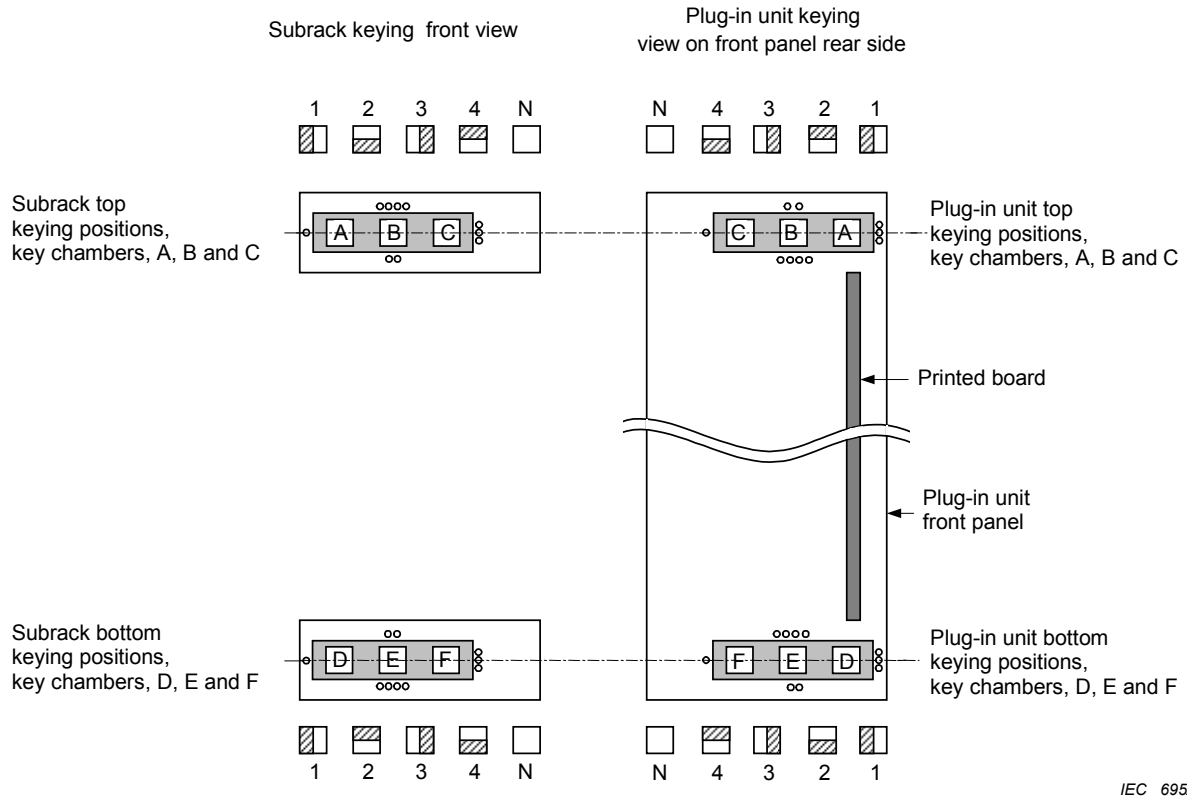

IEC 695/06

NOTE 1 On the rear of the subrack/plug-in unit, the letters A, B and C will be on the bottom and D, E and F on the top. The order of letters on the rear is a mirror image.

NOTE 2 Position marks show the key rotated position 1, 2, 3 and 4. "N" indicates a condition without key.

Figure 15 – Programming of keys

8.5 Keying chamber inspection dimensions

Table 1 contains the correct heights dimensions H_{SK} , which will insure the alignment of the two counterparts of the keying inserts.

Table 1 – Inspection dimensions of subrack and plug-in unit keying chambers

Dimensions in millimetres

SU	6	12	18
(H_S)	150	300	450
$H_{SK} \pm 0,3$	121	271	421

9 Alignment pin and/or electrical contact for front panels and plug-in units

9.1 General

The feature of the alignment and/or electrical contact is to align front panels in their position within a subrack (for example, for the use of shielding gaskets, see Clause 7 of this part of IEC 60917) or as a contact to the electrical receptacle on the subrack (see Figures 16, 17, 18 and 19).

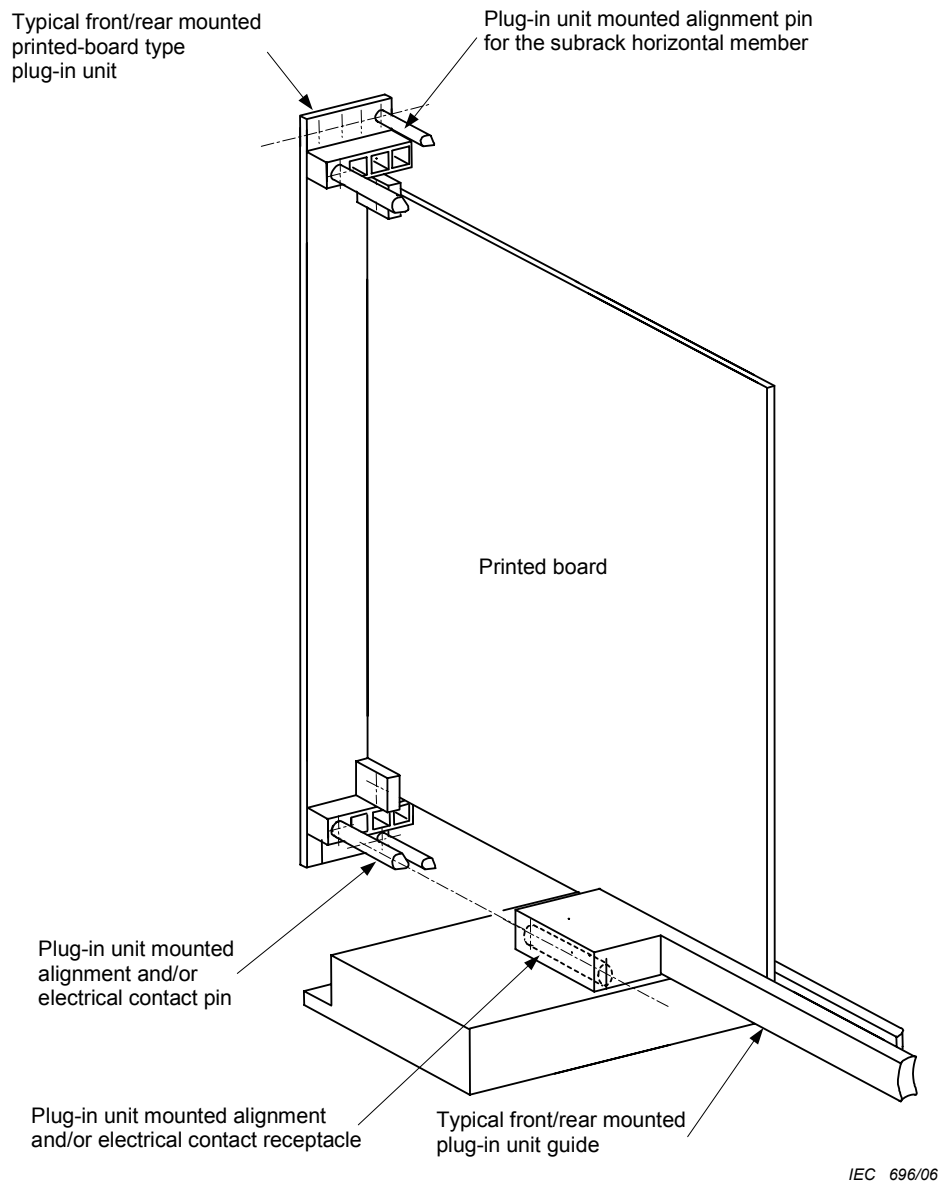
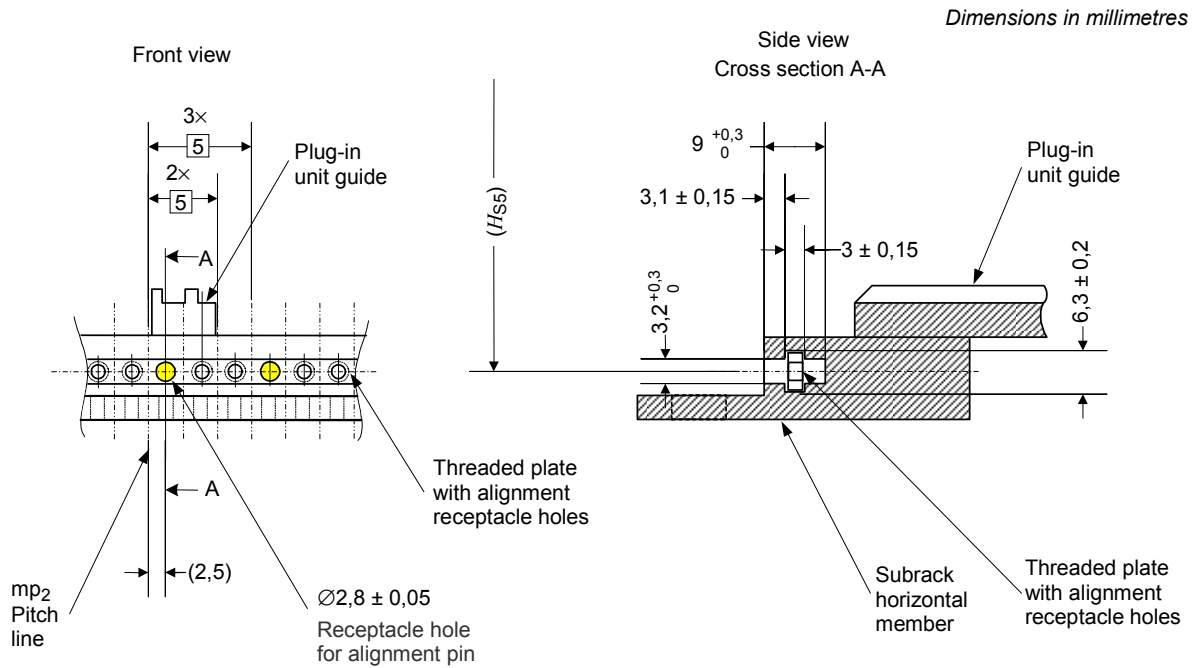

Figure 16 – Arrangement of alignment pin system for subracks and plug-in units

9.2 Alignment pins and receptacle plates on the subrack horizontal members

This alignment system shall be located at the area for the fastening arrangement between a subrack and plug-in units in accordance with IEC 60917-2-2 and Clause 11 of this part of IEC 60917. Therefore, in application of this alignment system, the plug-in units may have the injector/extractor handles with a locking function in accordance with 6.2, instead of the fixing by screws.



IEC 697/06

NOTE Dimensions in parentheses are in accordance with IEC 60917-2-2 (see Table 2).

Figure 17 – Subrack interface dimensions, alignment pins and receptacle plates on the horizontal members

Dimensions in millimetres

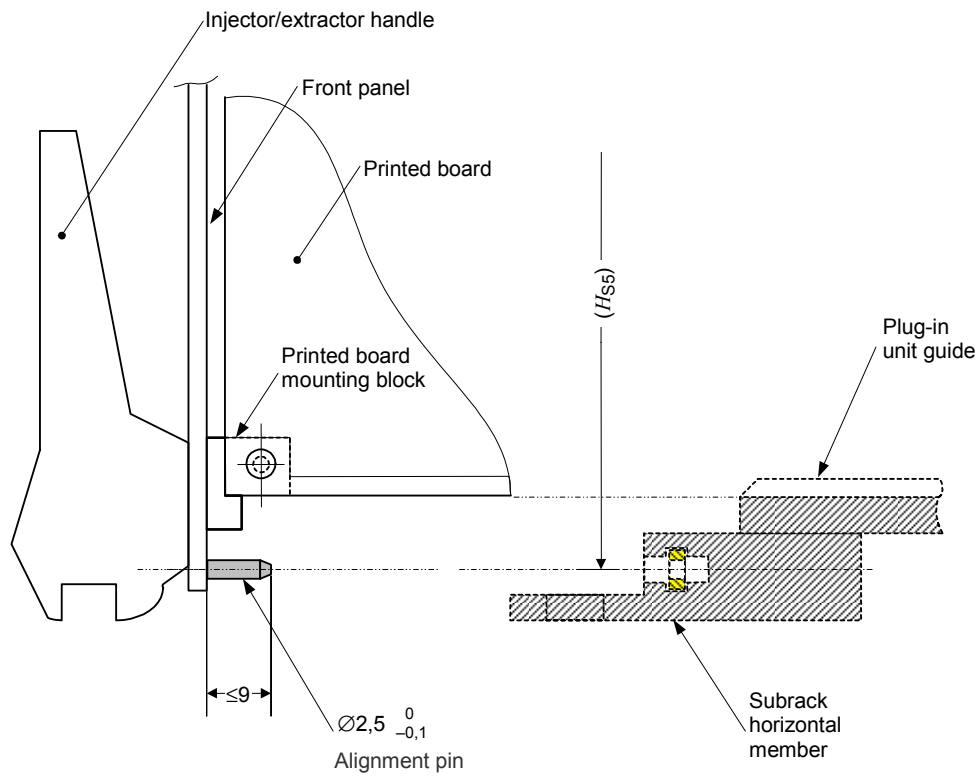

IEC 698/06

NOTE Dimensions in parentheses are in accordance with IEC 60917-2-2 (see Table 2).

Figure 18 – Plug-in unit interface dimensions, alignment pins and receptacle plates on the horizontal members

9.3 Alignment and/or electrical contact pins and receptacles on the subrack plug-in unit guides

9.3.1 General

This alignment and/or electrical contact system shall be located next to the key/coding system on the plug-in guides (see Clause 8).

The alignment function of this system can be used optionally instead of the alignment pins and receptacle plates on the subrack horizontal members (see 9.2).

The electrical contact by this system can be used as optional electrostatic discharge (ESD) contact between plug-in units and a subrack instead of the printed-board plug-in units ESD contact (see Clause 10).

A subrack assembled with guide rails in accordance with IEC 60917-2-2 and Clause 11 of this part of IEC 60917 (without the alignment and/or electrical contact features) will accept plug-in units with front panels fitted with the alignment and/or the electrical contact pin.

9.3.2 Subrack interface dimensions, alignment and/or electrical contact pins and receptacles on the subrack plug-in unit guides

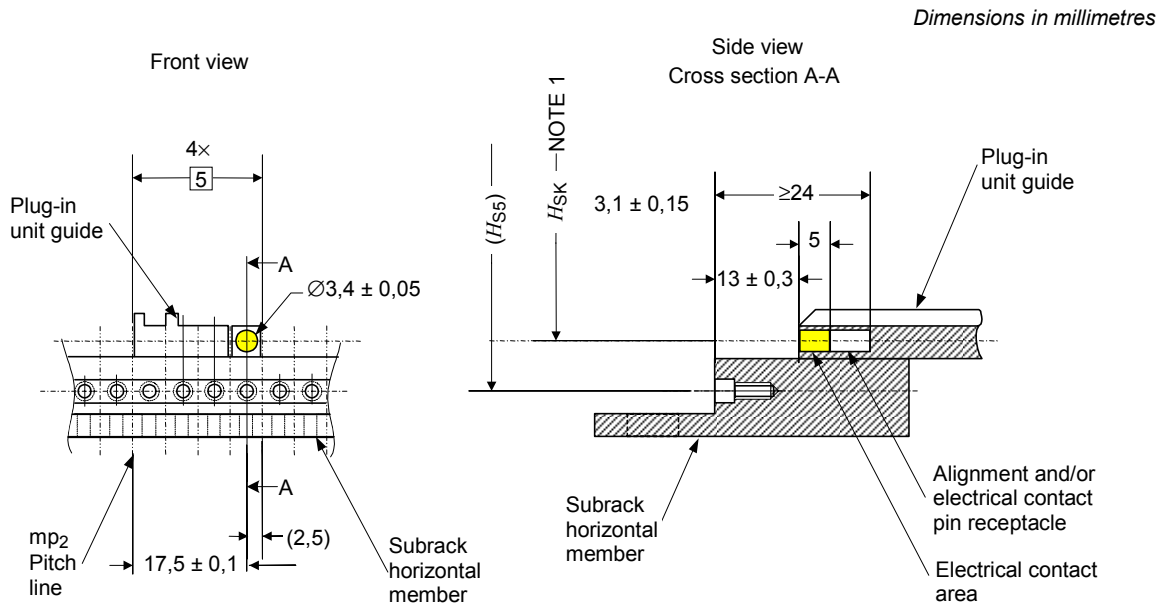

IEC 699/06

NOTE 1 For the H_{SK} dimension, see Table 1.

NOTE 2 Dimensions in parentheses are in accordance with IEC 60917-2-2 (see Table 2).

Figure 19 – Subrack interface dimensions, alignment and/or electrical contact pin receptacles on the plug-in unit guides

9.3.3 Plug-in unit interface dimensions, alignment and/or electrical contact pins and receptacles on the subrack plug-in unit guides

Figure 20 illustrates the alignment/electrical contact pin on the plug-in unit.

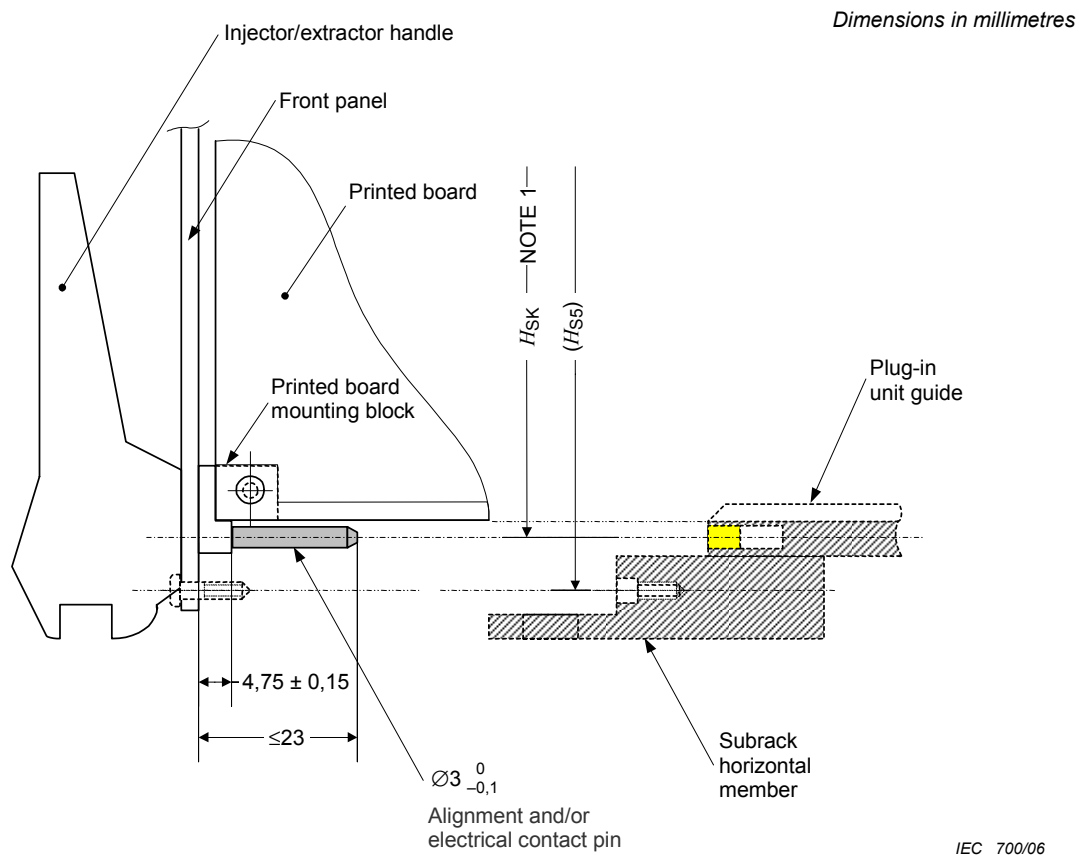

NOTE 1 For the H_{SK} dimension, see Table 1.

NOTE 2 Dimensions in parentheses are in accordance with IEC 60917-2-2 (see Table 2).

Figure 20 – Plug-in unit interface dimensions, alignment and/or electrical contact pin receptacles on the plug-in unit guides

9.3.4 Applications of the electrical pins and receptacles

The prime purposes of using the electrical contact pins and receptacles is for ESD protection of the plug-in units with front panels.

Electrical characteristics and their test methods of the electrical contact pins and the receptacles should be defined by the user's purpose and the application of the subrack and plug-in unit system based on this part of IEC 60917.

10 Electrostatic discharge provision for plug-in units and subracks

10.1 General

This clause defines the interface dimensions for an electrostatic discharge contact implementation of the guide rails and corresponding conductive strips on plug-in unit printed boards.

10.2 ESD contact interface dimensions

The ESD contacts shall be connected to the subrack horizontal members and the spring load fixed within the determined guide rail areas (see Figure 21). The ESD contacts shall be able to connect the inserted printed boards on both sides.

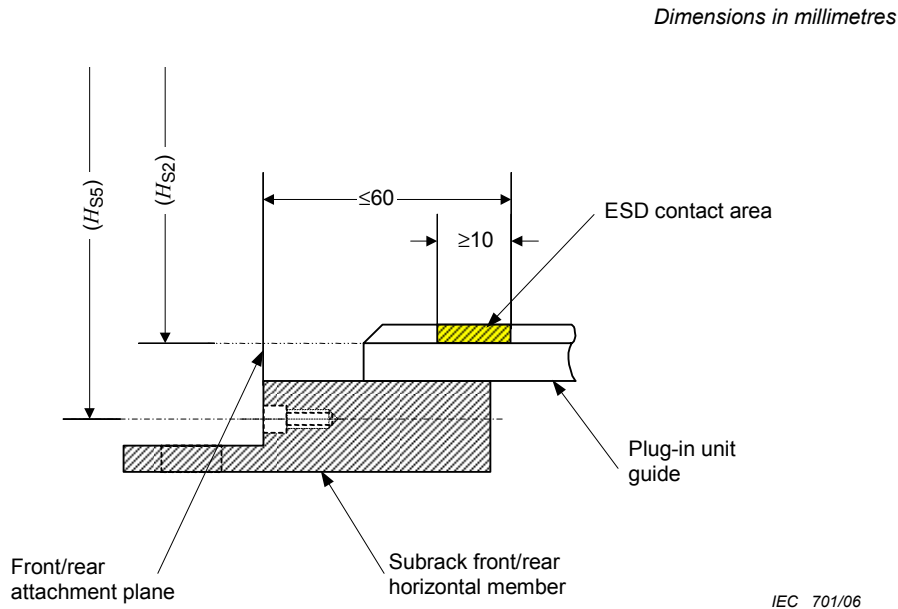

NOTE Dimensions in parentheses are in accordance with IEC 60917-2-2. See Table 2.

Figure 21 – Subrack interface dimensions, ESD contacts on the plug-in guides

10.3 ESD strip interface dimensions

Two types of ESD strips are defined for the printed boards of plug-in units. The first is the continuous discharge strip and the second is the interrupted discharge strip (see Figure 22).

The continuous discharge strip keeps electrical connections with the ESD contacts on the guide rails at the fully inserted position of the plug-in units in a subrack. The interrupted discharge strips release electrical connections with the ESD contacts on the guide rails after ESD of the boards, which are executed during insertion of the plug-in units into a subrack, at the fully inserted position of the plug-in units in a subrack.

Dependent on application needs the continuous or interrupted ESD strip type may be used.

Dimensions in millimetres

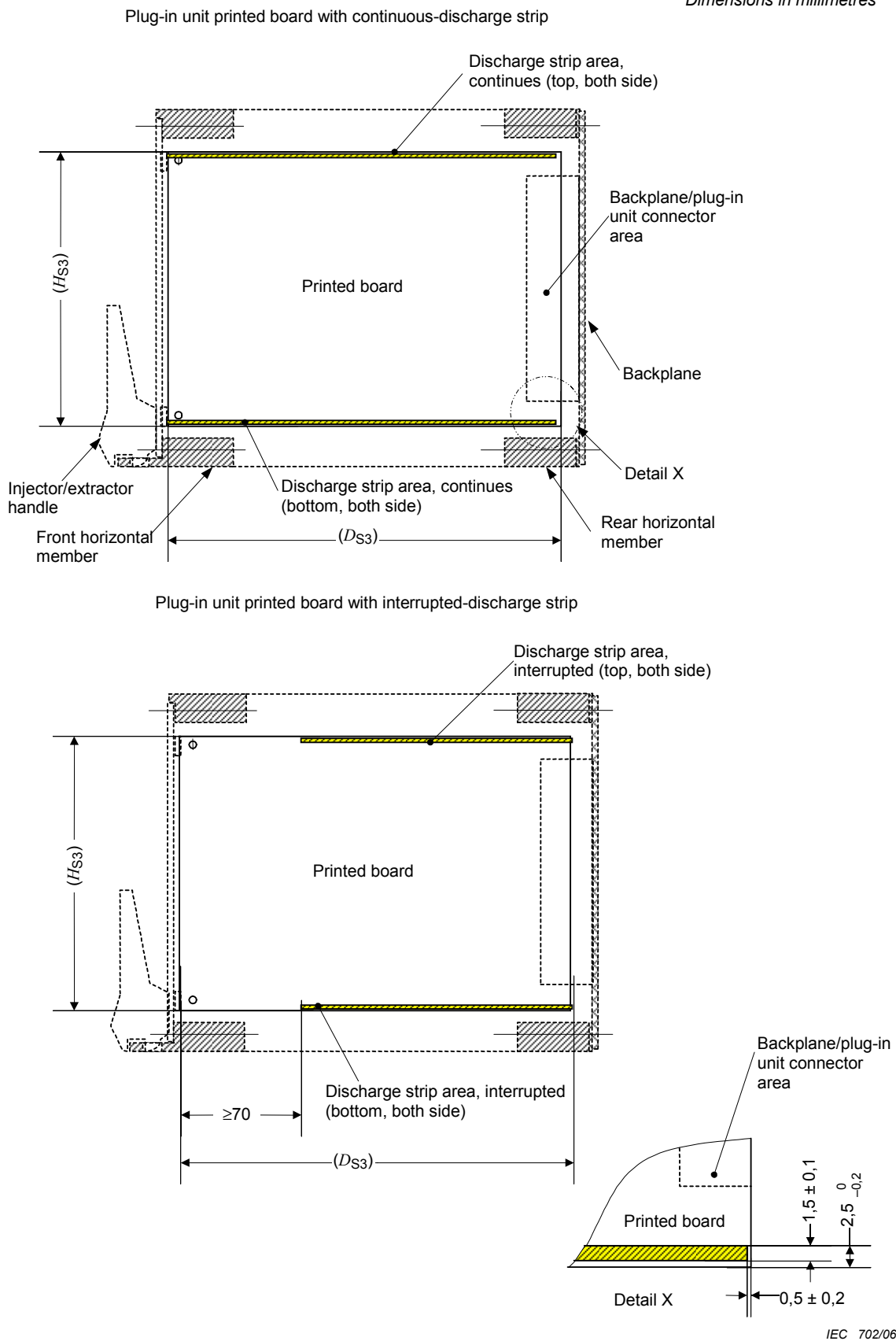

IEC 702/06

Figure 22 – Plug-in unit interface dimensions, ESD strips on the plug-in boards

NOTE Dimensions in parentheses are in accordance with IEC 60917-2-2 (see Table 2).

10.4 Dimensions of subracks and plug-in units based on IEC 60917-2-2

Dimensions of Tables 2a, 2b and 2c are in accordance with IEC 60917-2-2.

Table 2 – Dimensions of subracks and plug-in units based on IEC 60917-2-2

Table 2a – Height dimensions

Dimensions in millimetres

HB_{SB}	150	300	450	600
$HB_{S0B} \ 0/-0,8$	149	299	449	599
$HB_{S1B} \ >$	125	275	425	575
$HB_{S2B} \ + 0,6/- 0$	115,2	265,2	415,2	565,2
$HB_{S3B} \ + 0/- 0,3$	115	265	415	565
$HB_{S5B} \ U \pm U \ 0,35$	135	285	435	585
$H_{S7} \ \pm \ 0,35$	142	292	442	592
$H_{S8} \ \leq$	141	291	441	591
$H_{S9} \ \pm \ 0,5$	145	295	445	595
$H_{S13} \ \pm \ 0,1$	107	257	407	557
$H_{S14B} \ \leq$	100	250	400	550
where				
H_S	is the co-ordination dimension for subrack heights, $n \times mp1$;			
H_{S0}	is the subrack height or height of front panels on cabinets or racks;			
H_{S1}	is the aperture height of the subrack for plug-in units, $H_{S1} = (n - 1) \times mp1$;			
H_{S2}	is the guidance height of the subrack for plug-in units;			
H_{S3}	is the printed board height and male guidance height for frame or box type plug-in units;			
H_{S5}	is the mounting centre distance for plug-in units, front panels, backplanes and connector supports;			
H_{S7}	is the aperture height for plug-in unit front panels;			
H_{S8}	is the plug-in unit front panel height;			
H_{S9}	is the height of backplanes;			
H_{S13}	is the centre distance for mounting holes on printed boards and front panels;			
H_{S14}	is the usable space for components on plug-in unit front panels, between the printed board mounting flanges on the front panel.			

Table 2b – Width dimensions*Dimensions in millimetres*

$W_{S0} <$	450	500	625
$W_{S1} >$	425	475	600
$W_{S2} \leq$	483	533	658
$W_{S3} \pm 1,0$	465	515	640
W_{S4}	$n \times 5 - 0,3$		
where			
W_S	is the co-ordination dimension for subrack widths, $W_S = n \times mp1$;		
W_{S0}	is the subrack width;		
W_{S1}	is the aperture width of subrack for plug-in units, $W_{S1} = W_S - mp1$;		
W_{S2}	is the overall width of subrack including flanges;		
W_{S3}	is the mounting hole centre distance for cabinet front panels, rack front panels, subracks or chassis mounting flanges;		
W_{S4}	is the P-type plug-in unit front panel width.		

Table 2c – Depth dimensions*Dimensions in millimetres*

D_{SB}	175	225	250	300
$D_{S1B} +1/-0$	175,5	225,5	250,5	300,5
$D_{S2B} +0,8/-0$	174	224	249	299
$D_{S3B} +0/-0,3$	Connector dependent			
D_{S4B}	Connector dependent			
D_{S5B}	Connector dependent			
where				
D_S	is the co-ordination dimension for subrack depth, $D_S = n \times mp1$;			
D_{S1}	is the aperture depth of subrack for plug-in units;			
D_{S2}	is the subrack depth to rear attachment plane for fixed connector support or optional insulation strip, $D_{S2} = D_{S1} - 1,5$ mm;			
D_{S3}	is the depth of the printed board, connector dependent;			
D_{S4}	is the overall depth of box or frame type plug-in units, connector dependent;			
D_{S5}	is the plug-in unit depth, inspection dimensions, connector dependent.			

11 Subrack dimensions for rear-mounted plug-in units

This clause defines a range of rear-mounted plug-in unit printed board sizes and a subrack rear attachment plane for plug-in unit front panel (see Figure 23).

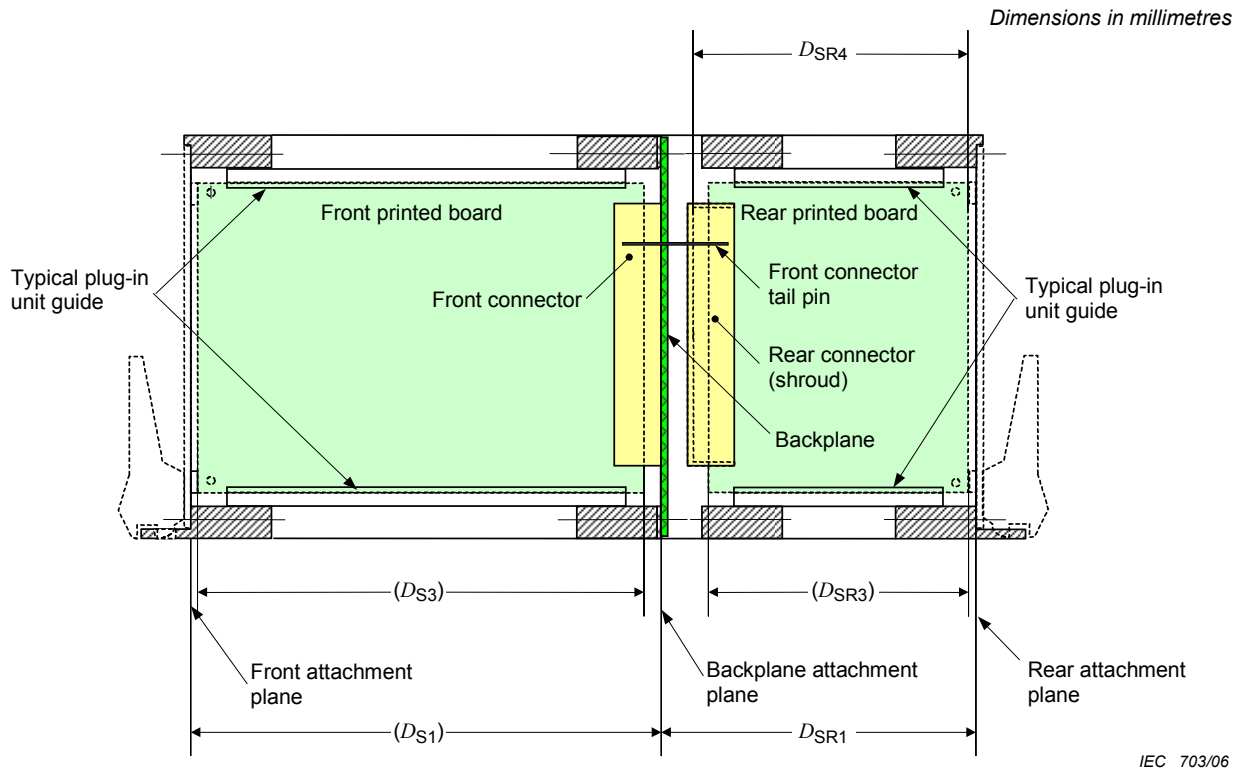

NOTE 1 $D_{SR1} = 100, 125, 150$ and 200 .

NOTE 2 Rear plug-in board depth (D_{SR3}) is dependent on connector types (see Table 3).

NOTE 3 Dimensions in parentheses are in accordance with IEC 60917-2-2 (see Table 2).

Figure 23 – Subrack dimensions for rear mounted plug-in units

Table 3 – Dimensions of subracks and boards for rear-mounted plug-in units

Dimensions in millimetres

	$D_{SR1} \pm 0,5$	100	125	150	200
IEC 61076-4-101 connector	$D_{SR3} +0/-0,3$	78,48	103,48	128,48	178,48
	$D_{SR4} >$	90,4	115,4	140,4	190,4
	$D_{SR3} +0/-0,3$	80,5	105,5	130,5	180,5
IEC 61076-4-104 Connector, with post- pin length $17,0 \pm 0,3$	$D_{SR3} +0/-0,3$	80,5	105,5	130,5	180,5
	$D_{SR4} >$	90,5	115,5	140,5	190,5

Annex A (informative)

Subrack, plug-in unit and backplane dimensions for using metric connectors

This annex gives the detail dimensions of the subrack, plug-in unit and backplane for the use of 2,5 mm and 2 mm metric connectors.

Figure A.1 shows an application of IEC 61076-4-100 connector in 6 SU 175 mm deep subrack.

Figure A.2 shows an application of IEC 61076-4-101 connector in 6 SU 175 mm deep subrack.

Figure A.3 shows an application of IEC 61076-4-104 connector in 6 SU 175 mm deep subrack.

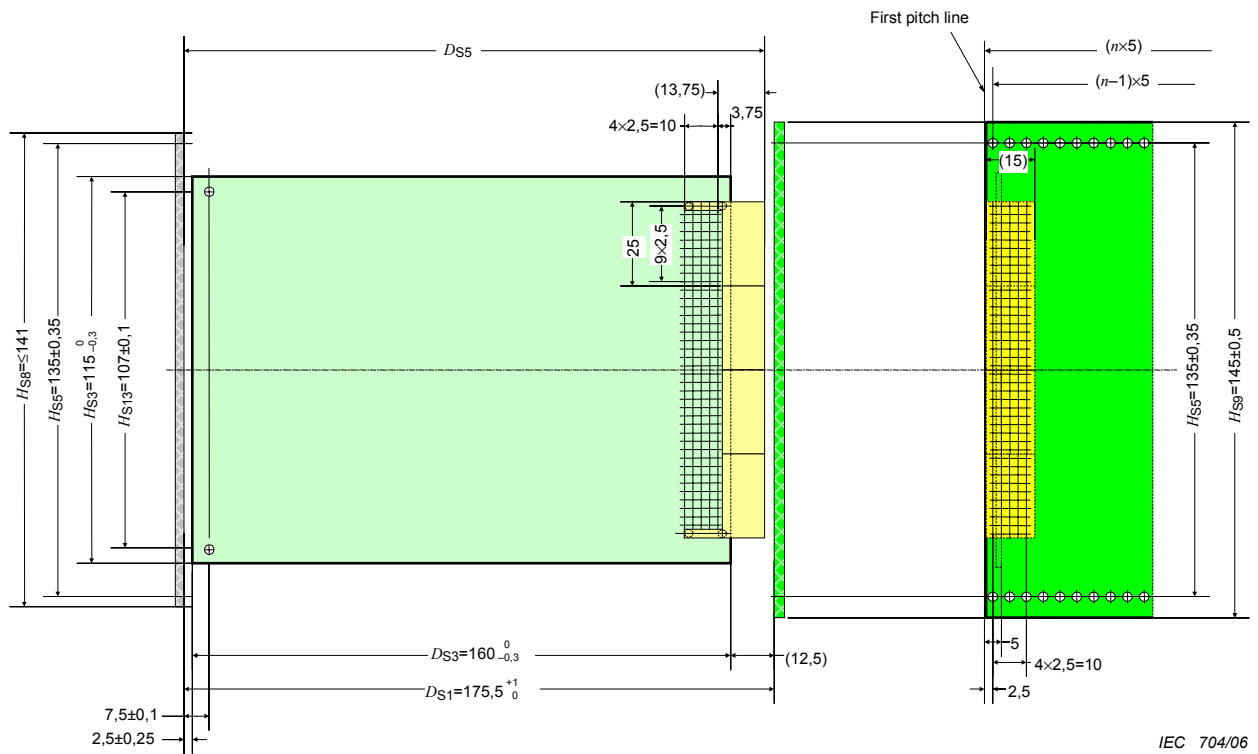

Dimensions in millimetres

**Figure A.1 – Subrack, plug-in unit and backplane dimensions
for using 2,5 mm metric connectors in accordance with IEC 61076-4-100**

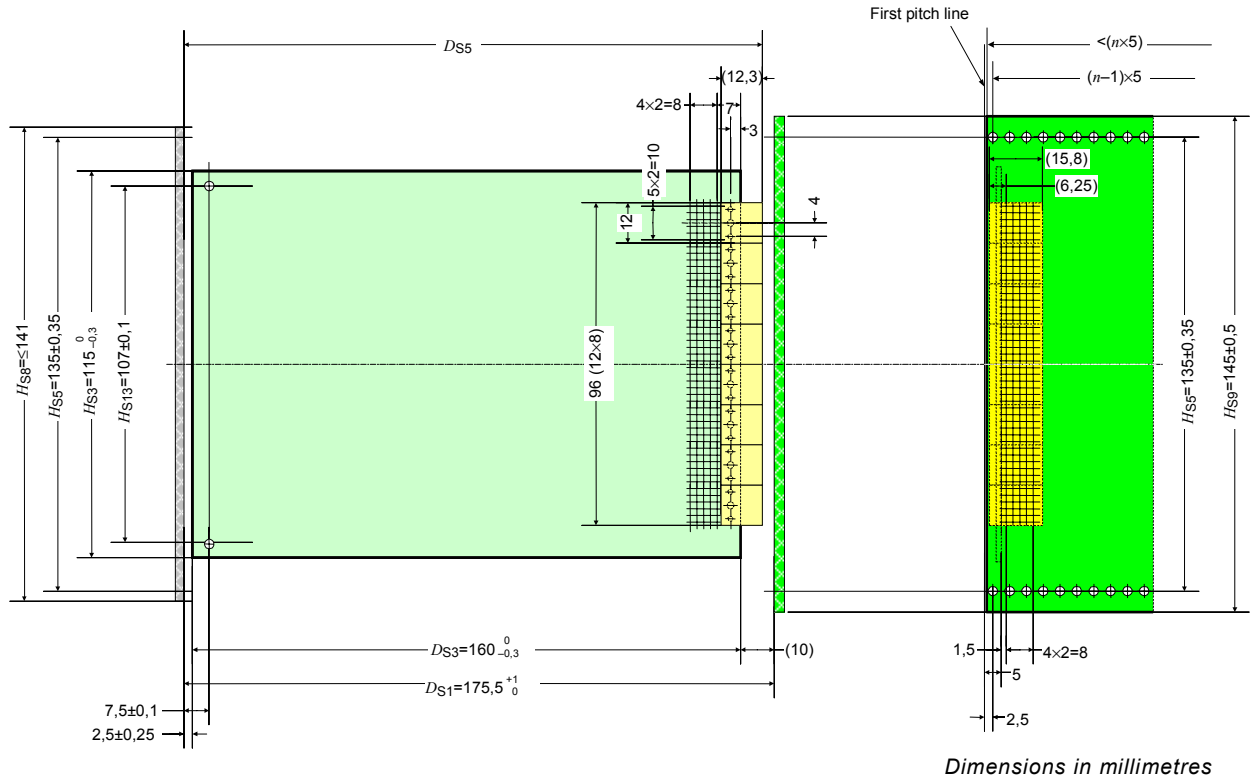
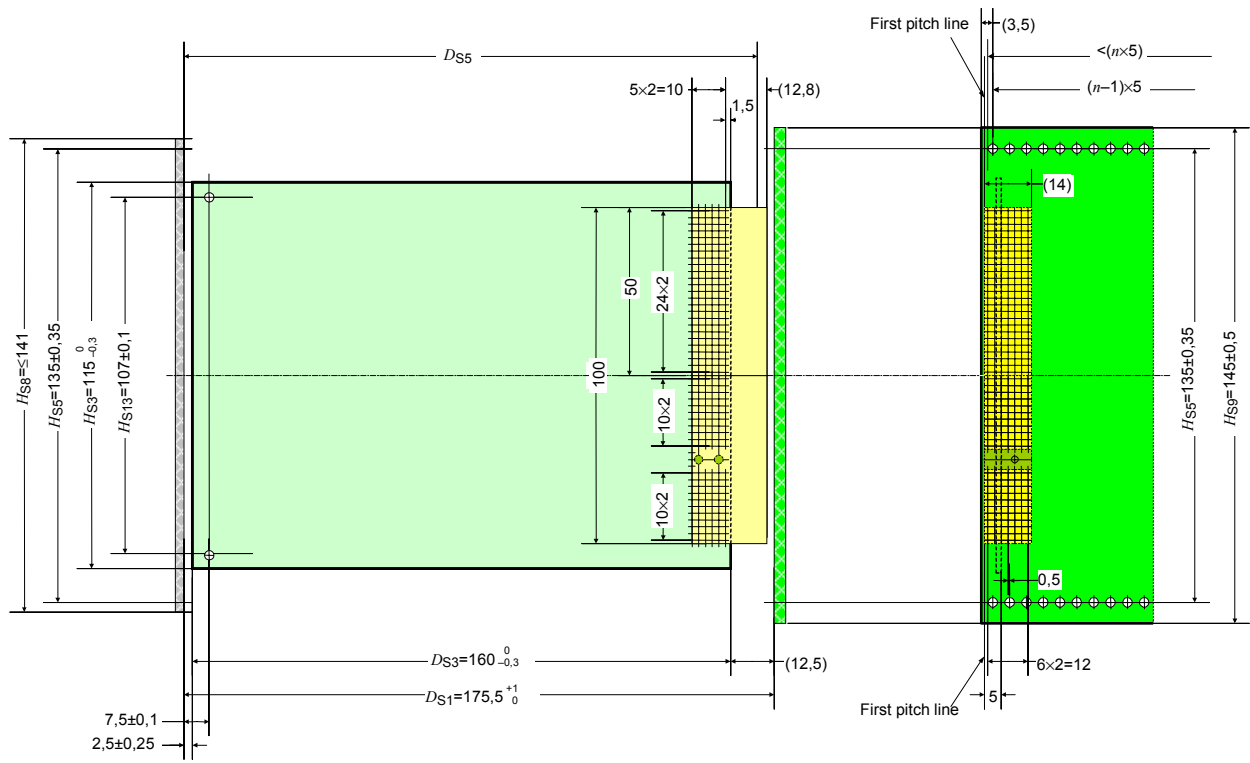

Figure A.2 – Subrack, plug-in unit and backplane dimensions for using 2 mm metric connectors in accordance with IEC 61076-4-101



Dimensions in millimetres

Figure A.3 – Subrack, plug-in unit and backplane dimensions for using 2 mm metric connectors in accordance with IEC 61076-4-104

LICENSED TO MECON Limited. - RANCHI/BANGALORE
FOR INTERNAL USE AT THIS LOCATION ONLY, SUPPLIED BY BOOK SUPPLY BUREAU.



Standards Survey

The IEC would like to offer you the best quality standards possible. To make sure that we continue to meet your needs, your feedback is essential. Would you please take a minute to answer the questions overleaf and fax them to us at +41 22 919 03 00 or mail them to the address below. Thank you!

Customer Service Centre (CSC)

International Electrotechnical Commission

3, rue de Varembé
1211 Genève 20
Switzerland

or

Fax to: **IEC/CSC** at +41 22 919 03 00

Thank you for your contribution to the standards-making process.

A Prioritaire

Nicht frankieren
Ne pas affranchir



Non affrancare
No stamp required

RÉPONSE PAYÉE

SUISSE

Customer Service Centre (CSC)
International Electrotechnical Commission
3, rue de Varembé
1211 GENEVA 20
Switzerland



Q1 Please report on **ONE STANDARD** and **ONE STANDARD ONLY**. Enter the exact number of the standard: (e.g. 60601-1-1)

.....

Q2 Please tell us in what capacity(ies) you bought the standard (tick all that apply). I am the/a:

- purchasing agent
- librarian
- researcher
- design engineer
- safety engineer
- testing engineer
- marketing specialist
- other.....

Q3 I work for/in/as a: (tick all that apply)

- manufacturing
- consultant
- government
- test/certification facility
- public utility
- education
- military
- other.....

Q4 This standard will be used for: (tick all that apply)

- general reference
- product research
- product design/development
- specifications
- tenders
- quality assessment
- certification
- technical documentation
- thesis
- manufacturing
- other.....

Q5 This standard meets my needs: (tick one)

- not at all
- nearly
- fairly well
- exactly

Q6 If you ticked NOT AT ALL in Question 5 the reason is: (tick all that apply)

- standard is out of date
- standard is incomplete
- standard is too academic
- standard is too superficial
- title is misleading
- I made the wrong choice
- other

Q7 Please assess the standard in the following categories, using the numbers:

- (1) unacceptable,
- (2) below average,
- (3) average,
- (4) above average,
- (5) exceptional,
- (6) not applicable

- timeliness.....
- quality of writing.....
- technical contents.....
- logic of arrangement of contents
- tables, charts, graphs, figures.....
- other

Q8 I read/use the: (tick one)

- French text only
- English text only
- both English and French texts

Q9 Please share any comment on any aspect of the IEC that you would like us to know:

.....



LICENSED TO MECON Limited. - RANCHI/BANGALORE
FOR INTERNAL USE AT THIS LOCATION ONLY, SUPPLIED BY BOOK SUPPLY BUREAU.

ISBN 2-8318-8622-8



9 782831 886220

ICS 31.240
